

# The Ultimate Guide to Float Level Sensors

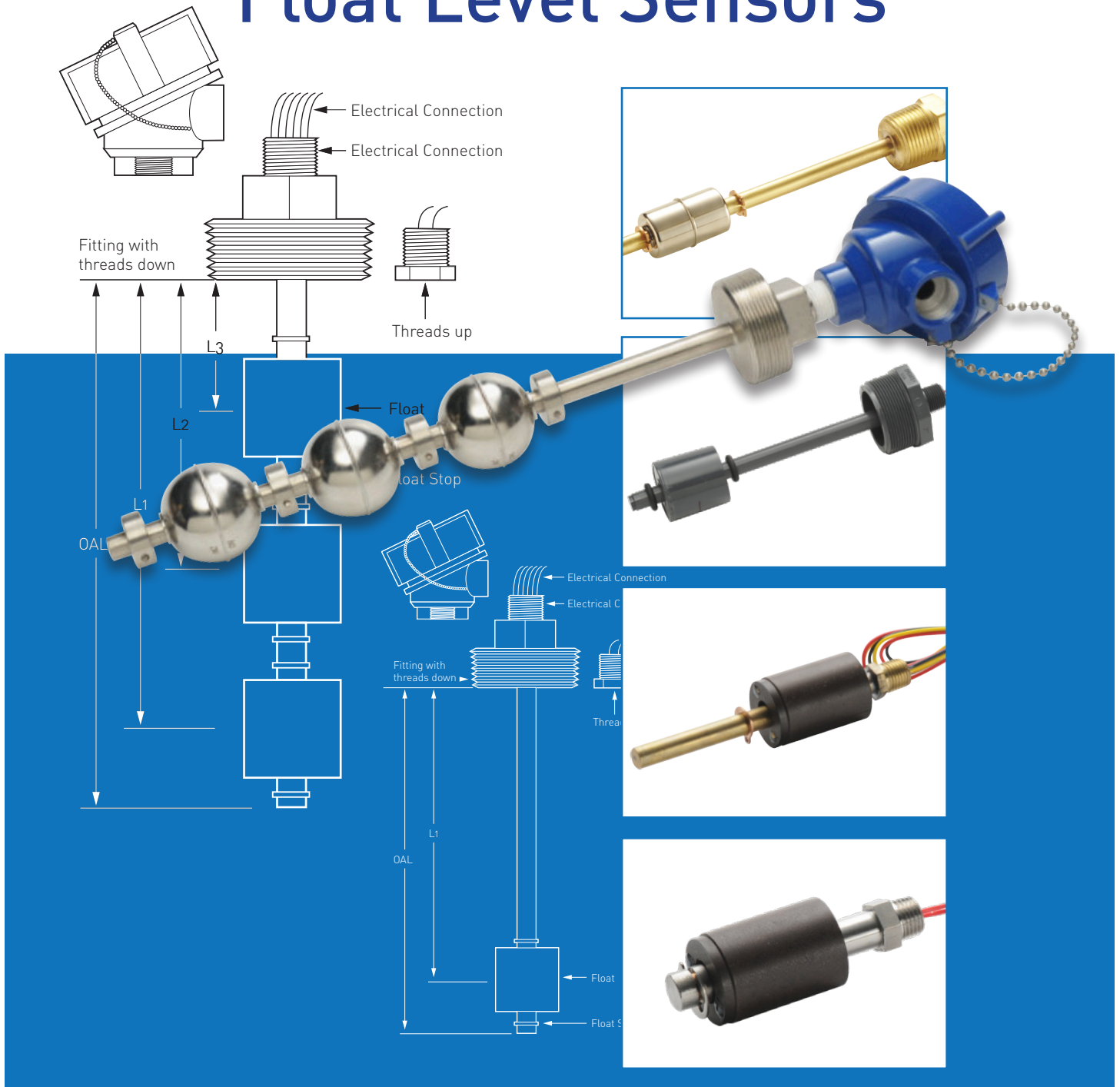

# Table of Contents

<b>Introduction</b> .....	5
Overview of level sensors, their use and selection .....	6
The float switch level sensor .....	7
The continuous level sensor.....	7
Magnetic float switch reliability .....	7
<b>Examples of level sensor use and applications</b> .....	8
Oil/water separators .....	8
Food processing equipment.....	8
Biotech.....	8
Chemical processing and storage .....	9
Commercial washers.....	9
Container level indication .....	9
Fuel management.....	9
Electroplating.....	9
Fluid power .....	9
Food and dairy.....	9
Freon recovery.....	10
Humidifiers and dehumidifiers.....	10
Lubrication equipment.....	10
Marine applications.....	10
Miscellaneous .....	10
Off-highway vehicles.....	10
Industrial parts washers.....	11
Power generation .....	11
Restaurant equipment.....	11
Semiconductor equipment.....	11
Solvent recovery.....	11
Waste oil and grease recovery .....	11
Water treatment equipment .....	11
Diesel fuel/oil tank and transfer systems.....	12
Medical equipment.....	12
Heating, ventilation and air conditioning .....	12
Heavy construction equipment .....	12

- How to select custom liquid level float sensors** ..... 12
  - What is the desired operation? ..... 12
  - What fluid type will you be measuring? ..... 13
  - Typical float switch materials ..... 13
  - What is the environment like inside and outside of the tank? ..... 14
  - What is your electrical load? ..... 15
  - How will the sensor be mounted? ..... 16
  - Are there tank restrictions? ..... 17
  - Design details and Options ..... 17
  - Pipe centering disc ..... 19
  - In summary... ..... 20
- Float switch and level sensor selection checklist** ..... 21
  - Liquid parameters ..... 21
  - Electrical requirements ..... 22
  - Mechanical component selection ..... 22-23
- Liquid level float switch installation guide** ..... 24
  - Basic instructions ..... 24
  - Installation quick check items ..... 26
  - 4 20 mA continuous level float sensors ..... 26
  - 0-5VDC continuous level float sensors ..... 27
- Maintaining a float style level switch** ..... 28
  - Inspections ..... 28
- Troubleshooting a float style level switch** ..... 29
  - Float is not positioned properly or moving properly ..... 29
  - Shock or damage to the floats or the sensor assembly (bent, dented, etc.) ..... 29
  - Excessive moisture around the wires exiting the sensor or connections ..... 29
  - Reed switch failure ..... 30
  - Float’s specific gravity does not match the liquid that is being measured ..... 30
  - Wire colors do not match the level switch ..... 30
- Troubleshooting a float style 4-20mA continuous level sensor** ..... 30
- Troubleshooting a float-style 0-5VDC continuous level sensor** ..... 31
- Procedure for reversing a float to change the Normal Switch State** ..... 31
- A brief history of float switches** ..... 32

# Table of Contents...continued

<b>APPENDIX 1: Hazardous location considerations</b> .....	33
Condition descriptions.....	33
Basics of explosion risks.....	33
Sources of ignition.....	33
The difference between intrinsically safe and explosion proof.....	33
Intrinsically safe equipment.....	33
Explosion proof enclosures.....	34
Intrinsically safe versus explosion proof: Advantages and disadvantages.....	35
Designing Intrinsically safe sensor circuits using simple and non-simple apparatus'.....	36
<b>APPENDIX 2: Understanding electrical ratings of float switches</b> .....	37
Reed switch ratings.....	37
Switching Resistive, inductive and capacitive loads.....	38
LOAD EXAMPLES:.....	38
Resistive load: Resistors, dry contact input, controllers.....	38
Capacitive Loads: Lead wires that exceed 200 ft, electrical equipment.....	38
Inductive Loads: Relay's, Solenoids, Light bulb.....	38
Designing for Inductive loads and Capacitive loads.....	38-39
<b>APPENDIX 3: Threaded Connections</b> .....	40
NPT assembly instructions.....	40
How to quickly determine the nominal size of a male NPT thread.....	41
How to determine the nominal size of an NPT thread.....	42-43

# Introduction

Float level sensors are both widely used and highly useful as the first-line input devices for many of today's electronic control systems for monitoring a tank's liquid level. From simple on/off pump control to highly sophisticated liquid level indication, float level sensors can be counted on to perform reliable and accurate liquid level measurement.

Although these devices are offered in many variations, almost all fall into two types depending on the output they provide. Switch type float level sensors provide an on or off signal at a specific liquid level. Continuous level float sensors provide analog data that is continuously updated as the liquid level changes.

## A note on terminology

Throughout this guide we will distinguish between these two general types of float level sensors devices by referring to them as *float level switches*, *liquid level switches* or *float switches*, and *continuous level float sensors*, or *continuous level sensors*.

Some of the other names used to refer to *float level switches* include: multi-level float switch, ball float, magnetically activated float sensor, liquid level sensor, and custom float sensor.

Other names that refer to *continuous level float sensors* include: 4-20 mA (or 0-5 Volt) liquid level transmitters, 4-20 mA (or 0-5 Volt) liquid level sensors, continuous level sensor, and float type 4-20 mA liquid level sensor.

## About this guide

The main body of this guide provides information on float level sensor technology and its applications. Additional detailed information about several important aspects of float level sensor selection and installation is presented in the appendices.

Our knowledgeable and experienced staff is always available to provide further information and can be contacted through our website, [www.RochesterSensors.com](http://www.RochesterSensors.com)

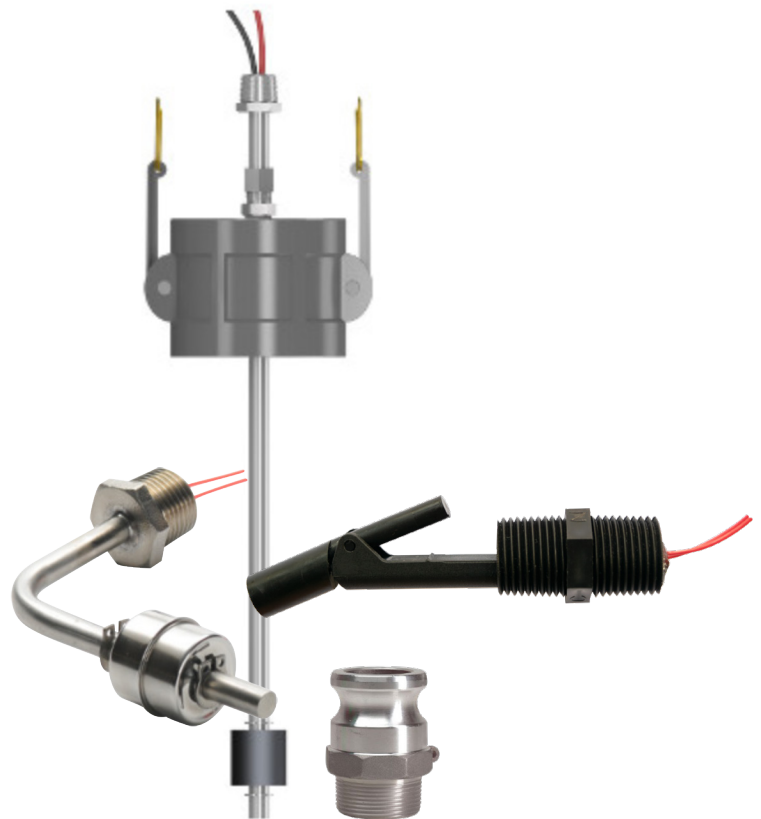

## Overview of level sensors, their use and selection

There are several different technologies and categories of level sensors. In each category, different types of level sensing is available. The main categories of level sensors are **mechanical**, **electro-mechanical** and **electronic**.

### Common mechanical level sensors include:



- Float switches
- Conductivity probes
- Dip rods
- Sight glasses
- Tape levels



### Common electro mechanical level sensors include:

- Float-style continuous level sensors
- Magneto restrictive continuous level sensors
- Resistance tape



### Common electronic level sensors include:



- Ultrasonic
- Guided wave radar
- Pressure sensors
- Laser sensors



This liquid level sensor guide focuses on **float-style liquid level switches and continuous level sensors**. Both types of **float level sensors** have floats that slide on a stem for accurate switch point measurement or continuous level measurement and typically are used in industrial applications. This guide also provides a step by step process to assist in selecting the best design for your float switch and continuous level sensor application. When selecting a float switch or continuous level sensor for your application, it can be very helpful to consider the questions included in the "How to select ..." section that follows.





## The float switch level sensor

A float switch is one of the devices most commonly used to sense liquid level. Although float switches are available in many styles, sizes, materials and with many options, they typically consist of a float with an internal magnet that slides up and down a stem containing hermetically sealed, magnetically calibrated switches. As the liquid level moves up and down in the tank, the float's magnet activates the internal reed switch at the designed point. The switch can be designed to turn on or turn off when activated. The float switch is used to close or open a circuit that is carrying small amount of current, typically at low voltage and amperage. This circuit generally is used to activate an alarm or provide a signal to turn a pump or valve on and off to fill or empty a tank.

## The continuous level sensor

Another model of a float-style liquid level sensor is a continuous level sensor, which provides a 4 20mA or a 0 5VDC continuous output signal. The signal is relative to where the float is located on the stem. Because the float will be at the surface of the liquid, the actual output signal is directly relative to the level of liquid in the tank. Continuous level sensors typically are connected to a programmable digital display or wired to a programmable logic controller.

## Magnetic float switch reliability

The sturdy construction of these float level sensors results in a trouble free, long operating useful life. When the effects of shock, wear and vibration are minimized, these hermetically sealed reed switches provide precise repeatability and consistent actuation points over the life of the float switch. When used properly, these magnetic float switches typically will exceed millions of cycles.

Engineers typically choose float style liquid level sensors because they are economical, reliable, simple and accurate. They are available with a tremendous amount of mounting methods and other options such as material selection, temperature monitoring and adjustability. For more information about how to select a float level sensor for your application, visit our website, [www.RochesterSensors.com](http://www.RochesterSensors.com)

*Freon Float Switch / LS-1198*



*0-5 VDC Continuous Level Sensor*

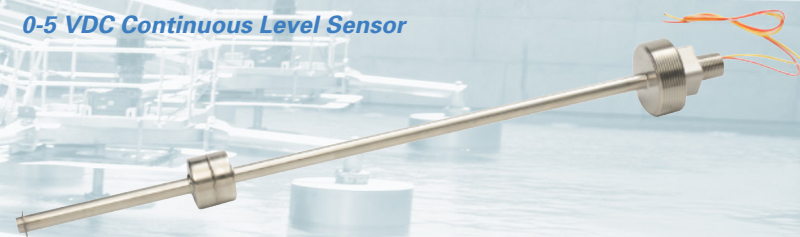

*3-Level Float Switch (FPO)*





# Examples of level sensor use and applications

Float-style liquid level sensors are used to perform various functions, including:

- **Regulating valves**
- **Turning pumps on and off**
- **Providing a signal to control panels**
- **Sensing low level**
- **Providing high level alarm**
- **Leak detection**
- **Overfill shutoff**
- **Level and temperature control**

Many different products and industries use liquid level float sensors, performing the tasks listed above and others as well, in a wide variety of applications. Such uses include, but are not limited to:

## Oil/water separators

Oil/water separation equipment benefits from using the float-style liquid level sensors because of their reliability and stable specific gravity. Floats are designed to float in water and oil or float in oil only, providing accurate switch points to turn pumps on and off and open and close valves. Rochester supplies liquid level switches to manufacturers of oil water separators. Applications include coalescing, emulsion breaking, and cylindrical gravity displacement.

## Food processing equipment

Level switches are used to meet the diverse needs of converters, food service and beverage company suppliers, food manufacturers and packagers worldwide. Level switches and temperature controls are typically found in storage vessels to control pumps and valves and for high level/low level alarm conditions. Level indicators are also used for continuous or multi-point monitoring.



## Biotech

Level switches are used for gene and protein research, drug discovery and development, and biopharmaceutical manufacturing. Custom designed products used in the biotech industry including DNA and hematology analysis systems where our products are used to detect the level of reagent.

*Continuous Level Sensor with Alarm*

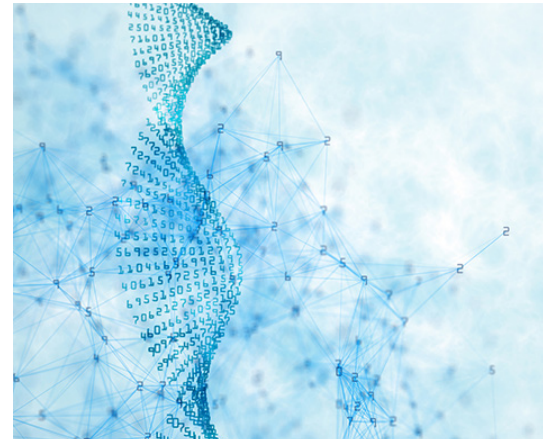

## Chemical processing and storage

Level switches are used in cleaners, lubricants, corrosion inhibitors, protective coatings, degreasers, greases, additives and liquid blending and packaging systems. Liquid level sensors are used in automated liquid handling systems to accomplish many tasks. Multi-level float switches control pumps, warn of dangerous level and temperature extremes, and keep operators informed of optimal conditions during normal operation.



*5-Level Custom Switch Sensor*





## Commercial washers

Liquid level switches are used in the commercial dishwasher industry in applications ranging from under the counter models in smaller applications to complete automated washing systems for larger foodservice operations. Level switches are used for high level and low-level alarms, heater protection, and automatic fill and drain applications.

## Container level indication

Custom designed level switches are used in several products for manufacturers of drums, liquid containers and intermediate bulk containers (IBCs). Level indicators are used to mechanically monitor liquid levels; level switches are typically used for pump/valve control and high/low level alarm conditions.

## Fuel management

Rochester has designed sensors for manufacturers of diesel powered portable and skid-mounted generators, large equipment and buses. Level switches and temperature controls are typically found in diesel fuel tanks for single point, multi-point, or continuous level monitoring.



*Two Level Custom Switch Sensors*



## Electroplating

Liquid level sensors typically are used for the electroplating and surface finishing industry to control a pump/valve to keep water at an acceptable level or to indicate an alarm situation.

## Leak Detection Float Switch



## Fluid power

Rochester manufactures several products for the fluid power industry. Some applications are assembly robotics, hydraulic systems on heavy equipment, tractors, spreaders, highway maintenance vehicles and automated manipulators.

Level switches and temperature controls are typically found in accumulators and reservoirs to protect against a high/low level or high temperature condition.

## Food and dairy

Food and dairy equipment regularly use custom and standard liquid level switches. Applications include milk storage vessels, oil extraction machines, storage silos, and other food processing equipment. Level switches and temperature controls are typically found in storage vessels to control pumps and valves and for high level/low level alarm conditions. Level indicators are also used for continuous or multi-point monitoring. Passivated 316L construction is available for food safe applications.

## Freon recovery

Rochester is a leader in liquid level switches for Freon and other refrigerant recovery systems. Freon float level sensors are commonly used to provide a 80% full shutoff in different sizes of refrigerant tanks. Brass and stainless-steel construction options are available. Common designs use 3 or 4 pin receptacles for a quick and easy connection.

## Humidifiers and dehumidifiers

Rochester has designed level switches for manufacturers of humidifiers, dehumidifiers and evaporative cooling systems. Level switches typically are used for high/low level conditions and pump/valve control.

## Lubrication equipment

We supply liquid level switches to numerous manufacturers of lubrication equipment. Applications include filter regulator lubricators (FRLs) and oil lube systems. Level switches and temperature controls are typically found in lube oil reservoirs. High and low-level alarms and pump or valve control are the two most common uses for level switches.

## Marine applications

Several liquid level switch products are used in the marine industry. Level switches can be found in cargo oil tanks, fuel oil service tanks, fresh water tanks, bilges, and void areas.



## Off-highway vehicles

Level switches and temperature controls can be found in such places as braking systems, transfer cases, windshield washer fluid, and hydraulic systems for off-highway vehicles.

## Industrial parts washers

Rochester provides liquid level switches to manufacturers of precision cleaning and aqueous parts washing machines. Level switches and temperature controls typically found in parts washers control pumps, warn of high/low level conditions, and provide heater protection. Level indicators also are used for continuous or multi-point monitoring.

## Power generation

Rochester is an industry leader in custom designed sensors for manufacturers of portable and skid-mounted generators. Level sensors typically are used for indicating the level of diesel fuel. Single point, multi-point or continuous monitoring sensors are available in multiple configurations to meet any application requirements.

## Restaurant equipment

Level switches and temperature sensors are purchased by manufacturers of restaurant equipment. Applications include food warmers, deep fat fryers, commercial freezers and coffee machines. Level switches are used in a wide range of applications including condensate overflow protection, and high/low level warning/shutdown.



*Four Level Custom Switch Sensors*

## Semiconductor equipment

Rochester supplies liquid level switches to manufacturers in the semiconductor industry. Applications include wet processing equipment, from manually operated to advanced, fully automated stations, wafer cleaning and etching systems. Sensors are constructed of Teflon to ensure accurate and reliable switching in the industry's most aggressive chemicals.



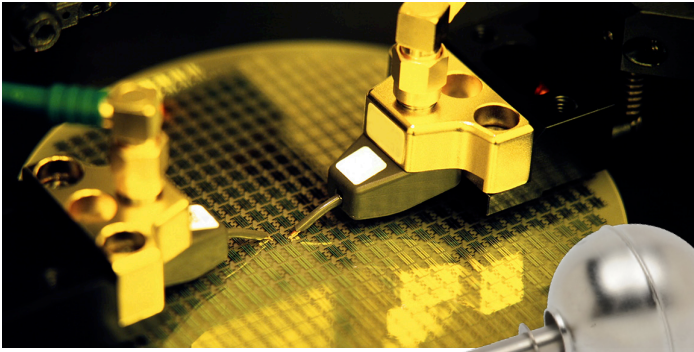

### Solvent recovery

Manufacturers of solvent recovery systems use level switches for high-level detection and/or pump/valve control.

### Waste oil and grease recovery

Manufacturers of oil skimmers and grease recovery/containment systems use level switches and temperature controls in recovery tanks for high/low level indication, pump control, and heater protection.



### Water treatment equipment

Custom liquid level switches are used by manufacturers of water treatment, purification, and reverse osmosis systems. Level switches and temperature controls typically are found in storage vessels to control pumps and valves and for high level/low level alarm conditions. Level indicators also are used for continuous or multi-point monitoring.

### Miscellaneous

When an application requires highly specialized products, Rochester will work with you to find a solution. Teflon coating, high temperature cable, and passivated wetted parts are a few examples of specialized OEM requests. Applications include inkjet printers, coffee makers, slush machines, reverse osmosis systems, and water coolers.



*Liquid Level & Temperature Sensor*



*Leak Detection Float Switch*



## How to select custom liquid level float sensors

There are many variables that go into selecting the best float switch or continuous level sensor design for a given application. When properly designed, installed and maintained, a float switch or continuous level sensor can be expected to last millions of cycles.

Float switches and continuous level sensors come in many styles, sizes, materials and offer many options. This guide provides a step by step process to assist in selecting the best design for your float switch or continuous level sensor application.

Begin by considering the answers to the following questions.

### What is the desired operation?

Initially, it is important to consider the function the float switch or liquid level sensor is to perform. For example, does your system require analog output for continuous level monitoring or a switch output for high level alarm, low level alarm or to turn a pump on or off?

**Continuous level:** If you require continuous level monitoring, check your control to see what type of input is required. Two common analog signals are 4-20mA and 0-5 VDC. Next, measure your tank to determine the range of measurement required. Continuous level sensors require a minimum upper deadband, a measuring range and a lower deadband. Deadband is an area where the sensor is not able to provide a reading. The standard minimum deadband is typically 1" for both the upper and the lower deadbands. However, if less deadband is required, certain considerations can be made to get closer to your application's requirements. The overall length of your sensor as measured from the face of the fitting to the end of the stem must be calculated to ensure the sensor will fit into your tank.

The standard overall length (OAL) is the measurement between the bottom of the fitting and the end of the sensor stem. The OAL is typically automatically calculated based on the Level 1 (L1) dimension. Special OAL's can easily be accommodated. See OAL Illustration.

*OAL Illustration*

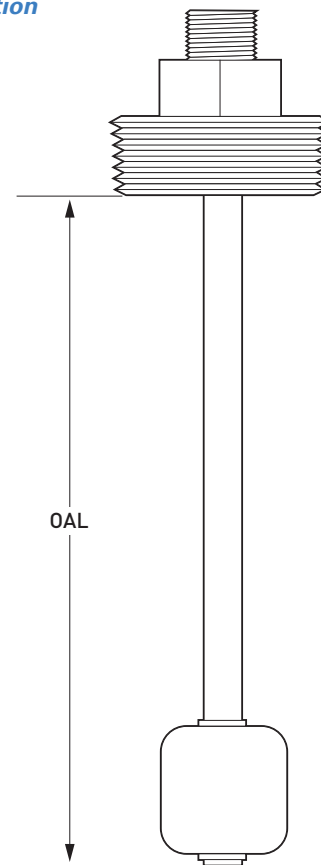

**Float switch output:** If you require a sensor with switch outputs, determine how many individual switch points you need to accomplish your functional requirements. Measure your tank to determine each switch point location. Take into consideration that the base of each sensor's fitting, the inside face nearest the floats (See Figure 1), is the reference point for all measurements. The industry standard is to



determine the desired “Normal” switch operation for each switch when the tank is empty (aka when the floats are away from the fitting). Single pole single throw (SPST) switches should be defined as either normally open (NO), which means the switch is open, or off, when the float is not floating, or normally closed (NC), which means the switch is closed, or on, when the float is not floating. Alternatively, single pole double throw (SPDT) switches are an option for providing both NO and NC switch operation. Note that the complexity and sensor costs increase with SPDT selection.

### What fluid type will you be measuring?

Most float switches and level sensors are designed to work in a variety of environments, but some are specifically designed with only one or two applications in mind. Knowing what you’re looking for will ensure the best selections are made for your application. Keep in mind that products can be made to meet your specific application requirements.

### Specific gravity

One of the main considerations when choosing a float switch is the specific gravity (sg) of your liquid. To make sure the float will function properly in the application – that it will actually float in your liquid – the specific gravity of the liquid must be greater than the float’s specific gravity at the maximum temperature of the application. Specific gravities of floats typically range from 0.45 to 0.93, depending on size and the material they are made of. In some applications, it is desirable to have a float that sinks in one fluid, such as oil or diesel fuel (0.7sg to 0.9sg), and floats in another, such as water (1.0sg). This is occasionally referred to as an interface float and has a specific gravity of 0.93. Custom specific gravity values are available in certain float materials.

## Materials

It is also critical to select a float switch that is constructed from the materials that are compatible with the liquids and potential chemical cleaning agents of the particular application. Component damage due to incorrect material selection can ultimately cause failure of a float switch. This is why it’s essential you read the data sheets for each product you’re considering.

### Typical float switch materials

**Stainless steel:** 316 stainless steel is a good material for high-temperature (to 300°F), high-pressure (to 800 psig) and corrosive conditions. It is commonly used in product cleaning and rinsing food processing, medical equipment, hydraulic fluids, fuel oils, heating and cooling equipment. These hollow floats are constructed of thin walled stainless steel.



**Buna-Nitrile:** Buna-N is a good material to consider for petroleum-based liquids, such as lubricating oils, gasoline and diesel fuels. It is widely used in fluid storage tanks for vehicles, generators, transmissions and hydraulic systems. Other uses are in lubrication, recovery, refining and fuel processing equipment. These solid Buna floats are very light and do not leak.



**Polypropylene (PP):** Polypropylene is a good material to consider for liquids containing acids and alkalis, detergents, inorganic and organic chemicals, water and acidic conditions, such as found in electroplating and metal cleaning. Another area of use is lower-temperature (to 180°F) food processing applications.

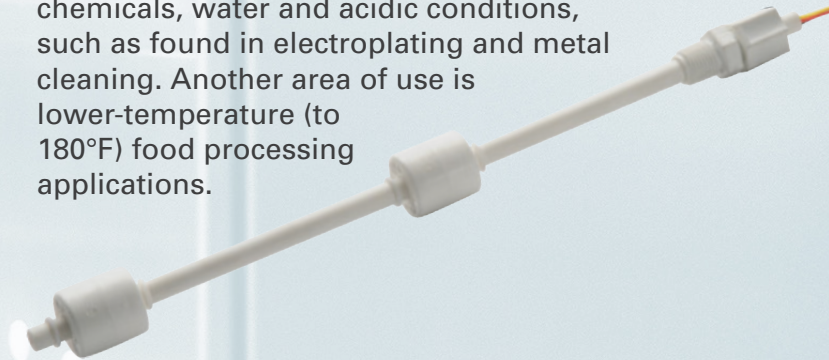

Polypropylene floats also are a good choice for general-purpose applications in commercial or consumer appliances and equipment. They are available both as solid floats (made of foamed polypropylene) as well as hollow floats molded with thin wall polypropylene.

**Kynar:** This is a good material to consider if harsh chemicals are used in your process. Kynar's solvent-resistant properties make this material a real problem solver for many applications. Its high-purity nature is ideal for food handling and sensitive laboratory or test equipment. The hollow floats are typically molded in 2 pieces and sonically welded together.

### **Chemical compatibility**

Selection of the most suitable materials for a float switch can be made by referring to a Chemical Compatibility table. There are several good chemical compatibility charts available on the internet, for example the Cole-Parmer chemical compatibility database. Simply do a search for "chemical compatibility of 316SS and sulfuric acid," for example. These tables provide a good indication of the suitability of the various float switch materials in a wide range of liquids. For some process liquids, it may be necessary to obtain a sample float switch to test the compatibility. Keep in mind that products can be manufactured to be compatible with nearly every liquid possible.

### **Viscous fluids**

Liquids with high viscosity do not flow readily, so floats used in viscous liquids should have a rounded shape to eliminate places fluid could accumulate or pool. It is important to ensure that the liquid's changing viscosity (with temperature or drying out or separating) does not interfere with the ability of the float to slide up and down the stem of the sensor.

### **Fluids with solids or magnetic particles**

It is important to determine whether solids, semi-solids or magnetic particles are present in your liquid. If they are, special considerations must be made to prevent these materials from causing problems with the float's movement and/or operation. An alternative design can be engineered so these materials have little to no effect on the float's operation. The trombone float style, for example, has a float attached to an extended arm that, when moved, triggers the switch function. This type of switch is ideal for use in heavy-bodied liquids or in fluids containing metal particles that would otherwise be attracted to a conventional style float.

### **What is the environment like inside and outside of the tank?**

#### **Temperature**

Your application's maximum and minimum temperatures must be determined to guide the sensor design selections. For example, 316 stainless steel is ideal for applications with temperatures to 300° F (and greater with special design considerations). On the other hand, polypropylene should only be used when temperatures will be 180°F or lower. Buna-N and nitrile, as well as other common materials, are rated to 180 F° maximum. Temperature extremes can affect the internal switches as well as the epoxy used to seal the end of the sensor.



## Pressure

Is your tank under pressure or vacuum? If so, what is the maximum pressure or vacuum? Different styles of floats and mounting fittings have different pressure ratings. Polypropylene and Buna floats, for example, typically have a pressure rating of about 150 psi. Stainless steel floats, on the other hand, can have pressure ratings of up to 800 psi.

## Vibration

Small vibrations typically have no impact on the float sensor's operation. Significant vibration has the potential to interfere with proper float switch operation and may result in erroneous signals. Turbulence can be caused by a vibrating tank, mixer agitation, or liquid swirling around as the tank is filled. Vibration and turbulence can cause erratic sensor operation. There are many design options available to protect sensor operation and reliability in an environment where significant vibration and or liquid turbulence is present.

## Sanitary applications or cleaning maintenance

Is your application a sanitary environment and or an application that requires occasional washdown? If so, the sensor should be designed to withstand the rigors of high-temperature, high-pressure caustic washdowns. It is important to identify the cleaning solution used as well as the washdown process. If the end of the sensor where the lead wires exit will be exposed to washdown, then waterproof NEMA 4X housings are a good option to consider.

## Outdoor locations

For outdoor applications, special attention must be given to the area where the lead wires exit the sensor and the conduit. An integrated outdoor rated NEMA 4X housing is a good option to consider. This option provides space to terminate your wires and protects the inside of the housing from the elements commonly found in outdoor applications.

## Hazardous locations

If your area is classified as a hazardous location, the correct device must be selected to ensure proper safety and meet your hazardous location requirements.

For more details regarding sensor selection for hazardous locations, refer to the appendix, "Hazardous location considerations."

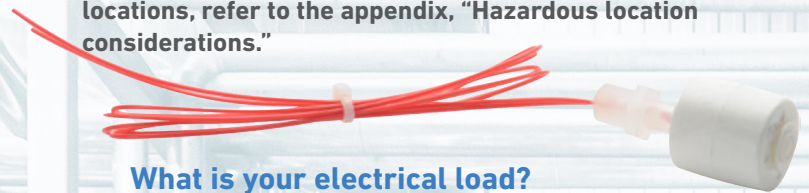

## What is your electrical load?

### Resistive vs. inductive loads

It is important to fully understand the nature of the load that needs to be switched and to ensure that the float switch is capable of handling this load. The electrical ratings most manufacturers provide in their float switch specifications typically are listed for resistive loads. Any loads that are inductive, such as a relay coil or light bulb, will potentially have inrush current and/or flyback power spikes. For these applications, determine the peak inrush current and voltage ratings to decide on the proper float switch rating. Inrush and flyback current often can be 10-50 times or more of the rated operating current. To switch a circuit where the electrical load exceeds the float switches rating, connect the load to an appropriate relay and wire the level sensor to control the relay operation.



### Electrical ratings

After the maximum load parameters are determined, the next step is to select a float switch with ratings that will meet your load requirements. Care must be taken so that your load does not exceed any of the maximum parameters of the float switch selected, including maximum wattage, maximum current (amps) and maximum voltage ratings. The most common float switch rating is a 50-watt switch with maximum "do not exceed" parameters of 1 amp, 265 volts and 50 watts. You must know two of these three values to determine if any of the values will be exceeded in your application using the formula  $\text{Watts} = \text{Volts} \times \text{Amps}$ .



For example, if your process runs on 120 volts and a 50 watt switch is used, it is important to determine the maximum allowable current for this switch.

To calculate this, simply divide the switch's wattage rating by the voltage of your process using the formula  $\text{Watts/Volts} = \text{Current (in amps)}$ . The maximum allowable current for this application would be  $50/120 = 0.4$  amps. In this case, if 120V is used, your load is limited to 0.4 amps (400mA) maximum. If switching an inductive load, the maximum parameters must be based on the inrush current.

**Refer to the appendix "Understanding electrical ratings of float switches" for more detail regarding surge protection devices.**

## Wire

Another step is to consider the type of wire or cable required for your application and the length needed. Common wire sizes for most float switch applications are 18 and 22 gauge. Teflon coated leads are typically standard and are suitable for most applications, however nearly any type of cable can be provided.

## How will the sensor be mounted?

The choice of mounting styles that may be suitable for an application will depend on the physical arrangement of the tank, the available mounting positions and whether access is available to the outside or inside of the tank. Make sure the fitting is large enough for the float to fit through the opening if the sensor is to be mounted from the outside top of the tank.

## Vertical vs. horizontal mounting

The main sensor mounting orientations are horizontal/side mount and vertical mount. The horizontal/side mount type normally has a threaded fitting, which passes through the sidewall of a tank with a hinged float attached to the stem. Vertical mount types normally have a vertical stem, which is installed through the top or bottom of a tank.

## Threads-up versus threads-down

If the sensor is to be mounted from inside the tank and you require a threaded fitting, a threads-up style fitting must be selected and you must make sure you have access to the inside of the tank. If the sensor is to be mounted from outside the tank and you require a threaded fitting, then a threads-down style fitting must be selected and proper size floats must be selected. Be sure that the floats will physically fit through the opening in your tank.

## Fittings

Common sensor mounting fitting types are NPT (tapered thread), BSPP (straight thread), SAE threads (straight) and flanges. Quick-connect fittings such as sanitary tri-clamp or camlock fittings are also common for applications where easy access is required for cleaning or testing of the float. Virtually any type of custom fitting can be supplied to meet your specific application requirements.

**For more information regarding NPT threading considerations, refer to the appendix, "NPT Connections."**





## Are there tank restrictions?

### Obstructions

It is important that nothing inhibits the movement of the float. Make sure the float sensor has adequate clearance of the tank walls as well as internal tank objects such as baffles, agitators, mixers etc.

### Magnetic Field Interference

Ferrous material mounted near the sensor can affect the magnetic field of the sensor and interfere with the sensor's operation. Be sure to design the tank fittings for sensor mounting to insure sensor's switch points or measuring ranges are not near ferrous materials or electromagnetic fields.

### Tank wall

For thick-walled tanks, or tanks with insulation, make sure the length of the float stem is long enough to reach into the tank so that desired level points are accurately achieved. For thin-walled tanks, make sure that the tank wall is strong enough to support the sensor assembly selected.

### Standoff

If the sensor is mounted on a standoff fitting, it is essential to adjust your level points or measuring range to offset the standoff mounting height. The sensor's overall length and the switch point dimensions are relative to the face of the sensors fittings, therefore the difference between the standoff fitting and the inside top of your tank will need to be taken into consideration for accurate sensor readings.

### Tall tank height

Tank height must be considered when selecting a float sensor. Custom suspended cable assemblies can be configured to operate on even the tallest tanks and silos. Compression unions can also be utilized for ease of installation and to minimize shipping costs on long length rigid stem float switch assemblies.

### Short tank height

If you have a very short tank with very tight switch points, you may want to consider what is commonly called a shared float switch assembly. Using a shared float, near-zero separation switch points can be achieved. This feature often is used on diesel fuel belly tanks, located on power generators where space often is limited and switch points must be very close to each other.

### Design details and options

Just about any option you require can be engineered into your float switch. Here are a few of the more common options available along with where and why they are used.

### Housings

Virtually any housing or enclosure can be provided to meet your application requirements. For wet or outdoor applications, integrally mounted NEMA 4X waterproof housings are recommended to protect the potted lead wires. For less demanding applications, watertight enclosures such as 3-hole outlet boxes, LB and SLB conduit boxes can be integrally mounted to your float switch for ease of wiring to your system.

### Displays

Various digital displays are available to meet both your digital and analog process requirements. These can be mounted either directly to a level sensor or mounted remotely.

### Wire, cable, seals

Teflon coated lead wire (24" long) are standard and suitable for most applications. If you need to customize the lead wire on a standard switch, a full range of value-added options are available. Common options are extra-long or short lead lengths; special wire or multi-conductor cable; ungrounded, grounded or shielded cable to eliminate electrical noise; shrink tubing for wire protection, terminations and connectors; cord grips and special sealing materials, such as Viton or Buna-N gaskets and O-rings, for applications where corrosive or caustic chemicals are present.



## Fitting and stem material

A variety of fitting and stem materials are available, including stainless steel, brass, PVC, polypropylene, Teflon and others. Custom materials can be provided to ensure chemical compatibility with your process.

## Fitting types and sizes

Nearly any fitting type and size can be provided. Some of the most common threaded fittings are NPT (tapered thread) in ¼", ½", ¾", 1", 1¼", 1½", 2", 3" and 4" sizes. Metric British Straight Thread (BST) and threaded bulkhead fittings are also common fittings. Common non-threaded fittings are 150 lb. flanges and fittings for quick-access, such as camlock fittings or 316 stainless steel Tri-Clamp sanitary fittings.

## Thread orientation

Threaded fittings are available as threads up or threads down. Threads up is used when installing a sensor from the inside of a tank. Threads down is used when installing a sensor from outside the tank.

## Float stops

Float stops are used to keep the float in the proper area to insure reliable sensor operation. Retaining rings are standard and suitable for most applications. For applications exposed to high vibration, caustic, corrosive liquids or where adjustability is required, stainless steel set collars may be a better option.

## Float materials and specific gravities

Floats can be provided in nearly any material you require. Some of the most common materials of construction are stainless steel, Buna, Polypropylene, Teflon and PVC. The specific gravity of the float determines how it floats in your liquid. The most common float specific gravities (SG) are 0.6 SG and 0.93 SG.

## Switch output types and ratings

Switch outputs are available as either single pole single throw (SPST) or single pole double throw (SPDT). SPST output types are the most common and are available with either normally open (NO) or normally closed (NC) contacts. Common switch ratings are 10 watts (500mA, 175 V), 50 watts (1 amp, 265 V) and 100 watts (3 amp, 265 V), with the 50-watt switch being the most commonly used switch. For applications where redundancy is desired, it is possible to build a liquid level float switch with side by side, redundant switches.

## Continuous level alarm output

High and low alarm switch output options are available on continuous level sensors. These alarms can be located above, below or within the measurement range.

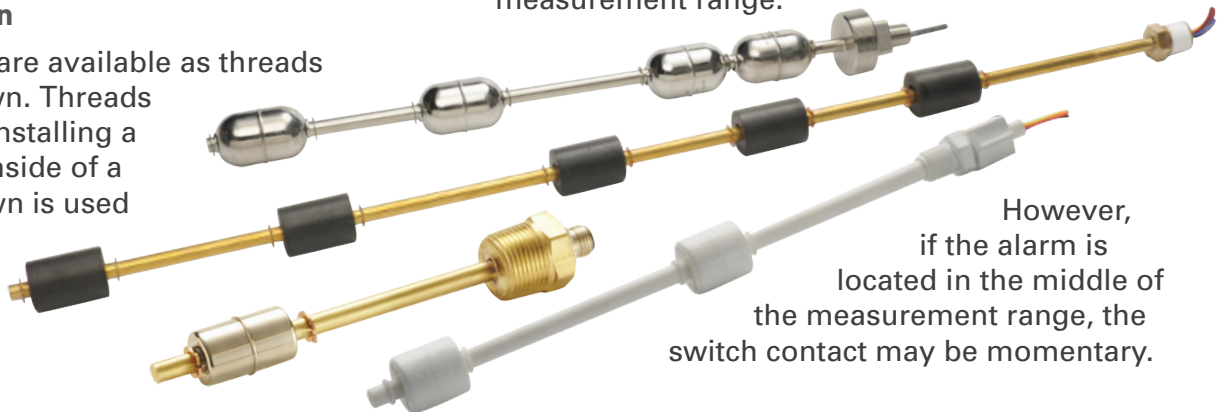

## Field adjustable stem length

When accurate positioning of the switch points is critical, a field adjustable stem option may be a good solution. These field adjustable stem lengths can help compensate for the variations in how far the NPT fitting's threads into the tank coupling. It also assists to accommodate variables in the overall tank depth. To obtain precise level measurement a field adjustable stem length option allows the stem length to be adjusted, in the field, to fine tune the exact switch actuation points. This feature is available as fully adjustable, which allows for repeat adjustments (Delrin ferrule), or as fixed adjustability (metal ferrule) which allows for a one-time adjustment. See adjustable illustration.

### Adjustable illustration

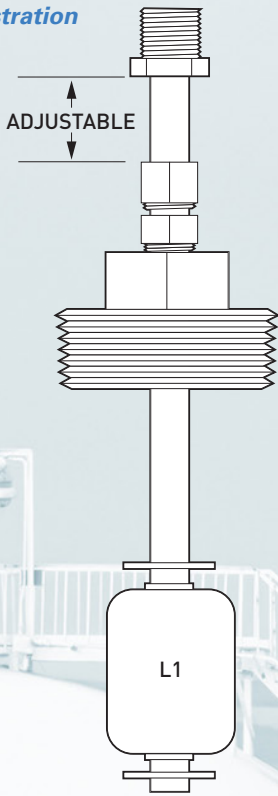

### Combined level and temperature sensing

Thermocouples, thermistors, resistance temperature detectors (RTDs), temperature switches and other sensing devices can be added and as built-in features of the level sensor. Such a combined sensor can reduce costs, minimize SKUs, reduce labor, improve reliability and can eliminate an entry point or use of another fitting on your tank.

For temperature switches, be sure to specify normally open (NO) or normally closed (NC) and the set point in degrees Fahrenheit.

### Slosh shields

A slosh shield is a low-cost solution that will protect a float switch from premature failure due to chattering and allow it to perform accurately in environments where intensive agitation or turbulence occurs.

### Pipe centering disc

For special applications where the sensor will be mounted in a stand-off pipe or stilling well, a centering disc would be a good option to consider keeping the floats centered in the pipe and ensure proper unrestricted operation.

### Suspended cable

For tall tanks and silos, a suspended cable option can be used to cover a large span providing ease of installation.

### Compression unions

Compression unions on stems are available on long length assemblies for ease of installation and to minimize shipping costs.

### Float test rod

This option allows for testing of the floats without having to remove the assembly from the tank. As shown on Figure 3, the push/pull test rod is accessible on the top of the sensor's mounting fitting. The remote push/pull rod feature saves time and money wherever scheduled testing of floats is required. See Test rod illustration.

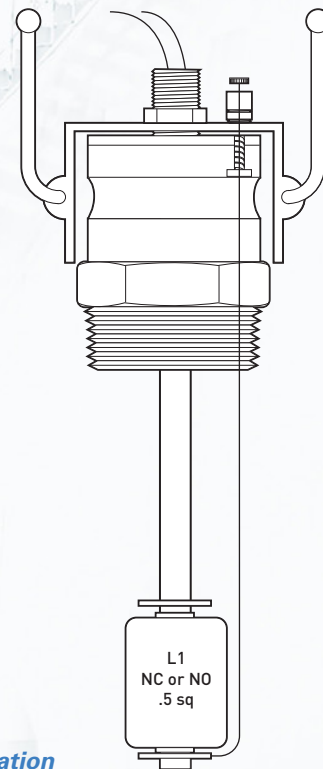

Test rod illustration

## Dual stem

Dual stem assemblies are basically two-float stem assemblies incorporated into one fitting. This option is a real problem-solver where limited mounting space exists, or where only one tank fitting is available and multiple or redundant switch points are required. It is most common to build each stem adjustable to fine tune each stems level setting. See Dual Stem illustration.

*Dual Stem illustration*

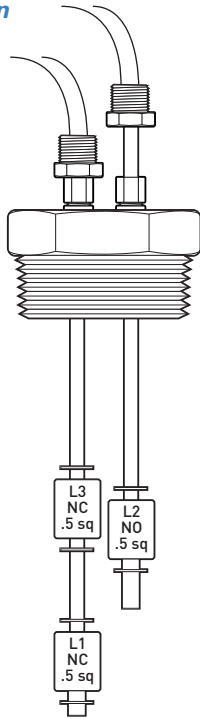

## Remote float

This design has a remote float attached to an extended arm that, when moved, triggers the switch function. This design is ideal for use in heavy-bodied liquids, liquids containing solids or in liquids containing metal particles that would otherwise be attracted to a conventional style float and cause fouling.

## Shared float

This option provides two switch outputs using one shared float. The result is a near-zero float spacing, which is a real problem-solver for applications where tight switch points are required. A shared float can also be used where redundant switch points are required.

## Hazardous locations

Intrinsically safe sensors and safety barriers are available for use in areas classified as hazardous locations.

**For more details regarding sensor selection for hazardous locations, refer to the appendix, "Hazardous location considerations."**

## In summary...

There are many choices for monitoring liquid level. Selecting the ideal sensor for an application can be difficult simply due to the number of options available. The challenge is determining the "best" option based on the application and design goals. One shortcut to finding a quick and successful solution is to work with a knowledgeable partner with broad product expertise and good application experience. By choosing to work with a leading sensor company, your design group can reduce risk, optimize resources, and speed development.



# Float switch and level sensor selection checklist

Here are the main questions that need to be considered when selecting a float level switch or continuous level float sensor for a particular application.

## Liquid parameters

What is the type and concentration of the liquid involved? \_\_\_\_\_

What is the specific gravity of the liquid? \_\_\_\_\_ sg

Are solids present in the liquid?  Yes  No

Will the liquid coat and build up on the float switch?  Yes  No

Are caustic or corrosive chemicals present?  Yes  No

If so, what is the concentration? \_\_\_\_\_%

Is the liquid surface turbulent or is tank vibration present?  Yes  No

What temperature range will the float switch be exposed to? \_\_\_\_\_ ° F Max. \_\_\_\_\_ ° F Min.

What is the maximum tank pressure/vacuum the float switch will be exposed to? \_\_\_\_\_ psi/vac

What function is the control to perform (example: keep tank full)? \_\_\_\_\_

Are switch output, continuous level output, or both required? \_\_\_\_\_

For switch output applications: What are the switch point locations on the tank (use the base of the sensors fitting as a reference) L1: \_\_\_\_\_", L2: \_\_\_\_\_", L3: \_\_\_\_\_", L4: \_\_\_\_\_", L5: \_\_\_\_\_", L6 \_\_\_\_\_", L7 \_\_\_\_\_"

SHOULD WE REFERENCE A DIAGRAM?  Yes  No

If a switch output is required, do you need SPST or SPDT? \_\_\_\_\_

If a SPST, do you need normally open (NO) or normally closed (NC) contacts? \_\_\_\_\_

For continuous level output applications: What is the measurement range required on the tank?

(use the base of the sensor fitting as a reference) \_\_\_\_\_"

Do you need 4-20mA or 0-5VDC analog output? \_\_\_\_\_

## Electrical requirements

What will the device be wired to? (example: PLC, relay) \_\_\_\_\_

What is the maximum voltage of the load? \_\_\_\_\_ VAC (or) \_\_\_\_\_ VDC

What is the maximum current draw of the load? \_\_\_\_\_ amps

Is the load resistive or inductive? \_\_\_\_\_

If an inductive load, what is the maximum inrush current? \_\_\_\_\_ amps

Is the location classified as a Hazardous location?  Y  N (see also appendix)

Will the float switch be located indoors or outdoors? \_\_\_\_\_

Are there any approvals required (i.e., UL, CSA)?  Yes  No

For more details regarding electrical loads versus ratings regarding sensor selection, refer to the appendix, "Understanding electrical ratings of float switches."

## Mechanical component selection

What is the maximum overall length (OAL) allowed to fit into your tank? \_\_\_\_\_" max.

### Specify an option from each category.

1. The float level sensor will be mounted from the:  side,  top,  bottom of the tank.
2. The sensor will be installed from the  inside,  outside of the tank.
3. Select mount fitting and size:  \_\_\_\_\_" Male NPT,  \_\_\_\_\_" Straight thread,  150lb Flange,  \_\_\_\_\_ Sanitary Flange,  Tube,  Quick Connect Cam Lock Fitting,  Other \_\_\_\_\_  
\_\_\_\_\_
4. Include a ½" conduit connection?  No  Yes

If yes, select:  Male or  Female.

Check desired construction materials: (other materials available)

- Brass,  Buna-N,  304 Stainless,  316 Stainless,  Polypropylene,  Polyethylene,  
 CPVC,  PVC,  PVDF,  Kynar,  Teflon

5. What is the desired float material? \_\_\_\_\_
6. What is the acceptable maximum size of the float (example: need to fit through mounting hole of .75") \_\_\_\_\_".
7. Electrical wiring to each switch will have:  individual wires  a shared common wire
8. Add an electrical junction box?  Yes  No
- If yes, box desired:
- NEMA 4X waterproof,  LB,  SLB,  3-hole outlet box,  other
9. Wire leads:  24" long (std.)  optional length \_\_\_\_\_"
10. Select desired type of Lead Wire:  PTFE insulated wire  Jacketed cable,  Shielded cable,  
 Other \_\_\_\_\_  Connector: type desired \_\_\_\_\_
11. Is a display needed?  Yes  No
12. Do you require field-adjustable positioning of the float stem?  Yes  No
13. If so, do you prefer fully adjustable (plastic ferrule) or one-time adjustability? \_\_\_\_\_
14. Is a built in temperature sensor desired?  Yes  No
15. Is remote testing of the float switch required?  Yes  No



# Liquid level float sensor installation guide

## Basic instructions

### Pre-Installation

1. Make sure the area of installation is free from hazardous or flammable materials. If not, then be sure to use appropriate enclosure and protection.
2. Confirm the pressure and temperature limitations of the sensor will not be exceeded.
3. Confirm that the sensors' materials are compatible with the liquid and environment in which the sensor will be operating.
4. Ensure that the electrical load placed on the sensor switches does not exceed its maximum ratings.
5. Minimize both shock and vibration to provide maximum sensor switch life.
6. Make sure the sensor is mounted in a tank area that is free of severe turbulence or is protected from such turbulence by appropriate slosh shields.
7. Inspect the sensor housing and electrical terminations to ensure they are clean and dry.
8. Inspect all components for damage and report any damage to the carrier within 24 hours of receipt.
9. Ensure that the length and the inside diameter of the mounting are sized correctly to accommodate the application.

### Handling

Be careful to not bend the sensor stem during installation. Most float style liquid level sensors have an internal, hermetically sealed glass switch(s) that can be damaged by bending. Also, be careful not to apply excessive shock or vibration to the sensor during installation.

### Mounting

Sensors typically are mounted with a female coupler at the top, bottom or side of the tank that has threads matching the sensor. Sensors can be mounted up to 30° off the straight-line orientation.

When threading metal threads into a metal coupling, pipe sealant or Teflon tape is recommended. To avoid potential compatibility problems, a compatible pipe sealant is recommended when sealing plastic threaded units. Engage the thread by hand, then use a wrench to rotate the sensor clockwise until it is tight within the mounting. When threading the sensor into the coupling, be sure to avoid overtightening, which can strip or damage the thread. The actuation points are typically measured from the face of the fitting, so the distance that the fitting is threaded into the coupling at installation will affect the exact actuation point(s).

### Wiring:

*When connecting the wires to the sensor, be sure to confirm the proper wire color. Take care when handling the wires and feeding the wires through conduit or tight spaces to insure lead wire insulation is not compromised or damaged. Do not allow lead wires to be contacting sharp metal surfaces. It is important that lead wires are terminated in a controlled environment (inside a housing or enclosure) or terminated with a weather proof termination. Make sure the point where the insulation is removed from the wire is not exposed to high moisture content as the space between the wire and the insulation can leach moisture into the sensor. It is best practice to route the sensor wires in their own conduit with a reasonable separation from high power wires to minimize electrical noise problems.*

## Contact protection

To maintain the life and reliability of the internal reed switch, it is essential to provide protection when switching inductive loads. In an inductive load, when the switch opens the energy stored in the load can generate high frequency voltage spikes across the switch contacts. (known as “Fly Back” power) If the power is large enough, it can initiate arcing and weld the contacts together. Damage can be minimized by suppressing the voltage and current spikes. In some applications, a relay is required to isolate the float switch from a large load. In this scenario, the float switch will be connected in series with a relay input coil that will activate the main relay contacts typically draws less than 500 mA. When the float switch is closed, the relay coil is activated and closes the relay output contacts. These contacts turn on or off the high current required by the large load, such as a pump.

## Moisture protection

The lead wires exiting the sensor are typically potted with epoxy. Although this potting provides some protection to the interior of the sensor, if moisture is present in the conduit, there is a potential for this moisture to wick down the wire leads into the sensor’s internal assembly where the moisture can contaminate the internal wire harness and switches resulting in the failure of the sensor. Keeping the moisture away from the area where the leads exit the sensor and away from the area where the insulation is stripped from the lead wire will help minimize this potential problem. See Conduit illustration.

When running conduit to the sensor, be sure to run the conduit below the connection point to the sensor to create a water trap (like a sink drain trap) This trap will collect the condensation build up, preventing the moisture from accumulating on the end of the sensor where the leads exit.

## Conduit illustration

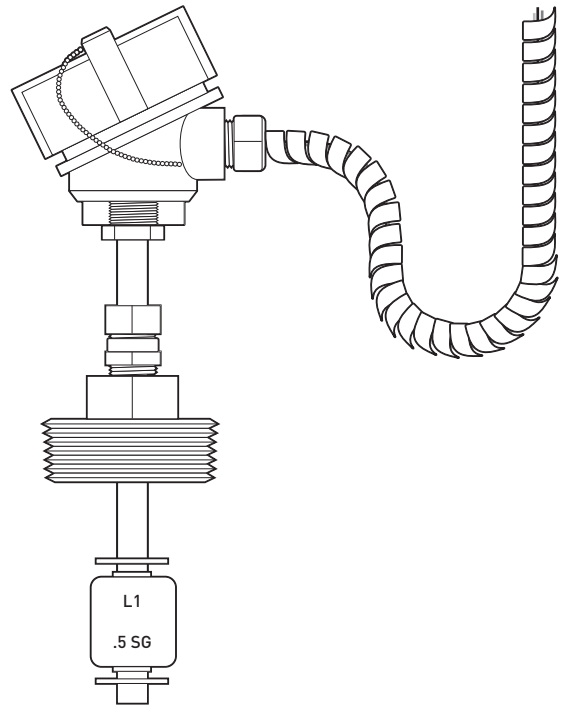

There are design options that can be considered to protect the sensor from moisture contaminating the internals of the sensor. One popular option is to select a cable for lead wires and a sealed “cord grip” to create a water tight seal at the end of the sensor. There are other options create a water tight sensor. Contact Rochester to discuss your specific application requirements.

## Compression tube fittings installation procedure

Compression fittings are typically found on units with the field adjustable stem length option and long sensors that exceed 100" or sensors where installation clearance above the tank is limited. For an adjustable sensor, loosen the compression fitting and slide the stem so the floats are at the desired depth in the tank and then tighten compression fitting. For tube connections, loosen the nut on the fitting and insert tubing until the tube bottoms in the fitting body. Tube alignment with fitting is very important. Tighten nut finger tight, then wrench tighten 1¼ more turns).

## Installation quick check items

1. Confirm the peak electrical load across the sensors switches do not exceed the switch's maximum rating
2. Confirm the maximum temperature of the system does not exceed the maximum temperature rating of the sensor
3. Confirm the pressure in the tank does not exceed the maximum pressure rating of the sensor
4. Be sure there is not ferrous material near the sensor. Nearby (as a guideline, within 6 inches, however further separation may be required for certain sensors) ferrous material can disrupt the sensors magnetic field and interfere with the sensors operation.
5. Confirm the wiring and conduit are properly installed to insure moisture does not accumulate in the area the leads exit the sensor and the lead wire connections are protected against moisture contamination.

## 4 20 mA continuous level float sensors

### Installation

When initially installing the continuous level sensor, mount the sensor into the tank with the matching fitting. When threading metal threads into a metal coupling, pipe sealant or Teflon tape is recommended. After the sensor is mounted in the tank, add the conduit. Use only appropriate conduit hubs that are specified to maintain the desired UL/CSA rating. For more information see

### CL Wiring Diagram

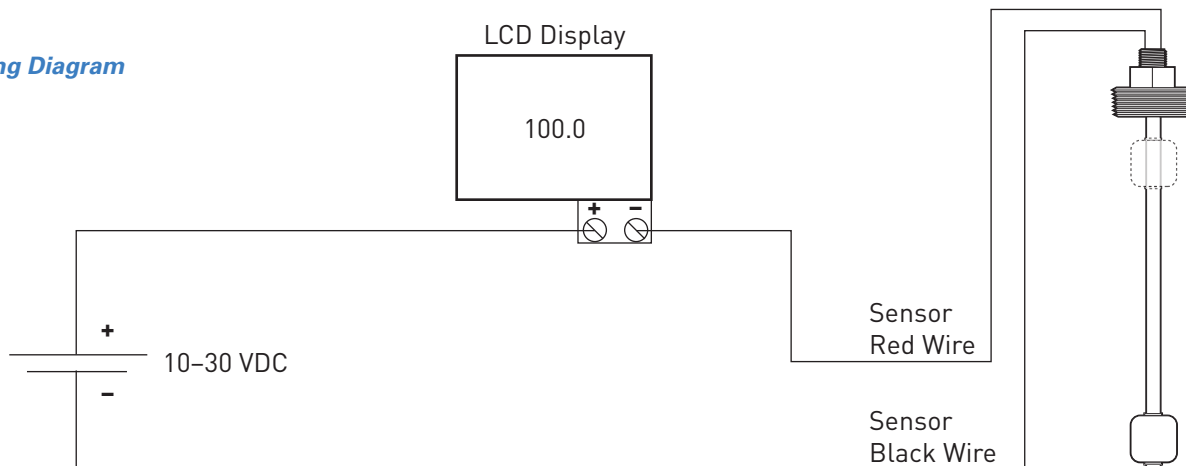

the "Liquid Level Float Sensor Installation Guide" section.

This sensor should be wired by qualified, licensed technicians (CL wiring diagram). The 4-20mA loop powered sensor has two wires exiting the housing of the sensor. The red wire connects to signal (or + VDC), the black wire connects to - VDC. To protect the sensor, we suggest the power supply be wired with a fast blow fuse rated between 30mA and 100mA.

### Operation

The 4-20mA sensor operates on a loop power or a separate power supply of 10-30 VDC. The sensor will provide a linear output between 4-20mA across the measuring range. When the float is at the bottom of the measuring range (furthest away from the fitting) the signal output will be 4mA. As the float moves closer to the fitting, the mA output will increase until it reaches the top of the measuring range, providing a 20mA signal. The mA signal will change every 1/4" of float movement. The mA value will change with every 1/4" of float movement. The value of mA change per 1/4" of float movement equals 4 divided by total measuring range in inches.

Our loop powered 4-20mA sensors are reliable and easy to install. These sensors will arrive at your plant, ready to install into your equipment. No calibration is needed. Simply install into your tank and connect the two wires — that's it. These sensors are tough. They are used in demanding applications with years of reliable, accurate performance. There is no drift and they never need calibration.



## 0-5VDC continuous level float sensors

### Installation

When initially installing, mount the sensor into the tank with the matching fitting. When threading metal threads into a metal coupling, pipe sealant or Teflon tape is recommended. After the sensor is mounted in the tank, add the conduit. Use only appropriate conduit hubs that are specified to maintain the desired UL/CSA rating. For more information see the "Liquid Level Float Sensor Installation Guide" section.

This sensor should be wired by qualified, licensed technicians (0-5 VDC CL sensor wiring diagram). The 0-5vdc continuous level sensor has three wires exiting the sensor. The red wire connects to the + of your meter or controller, the white wire connects to + VDC, the black wire connects to - VDC and the - of your meter or controller. To protect the sensor, we suggest the power supply be wired with a fast blow fuse rated between 30mA and 100mA.

### 0-5 VDC CL sensor wiring diagram

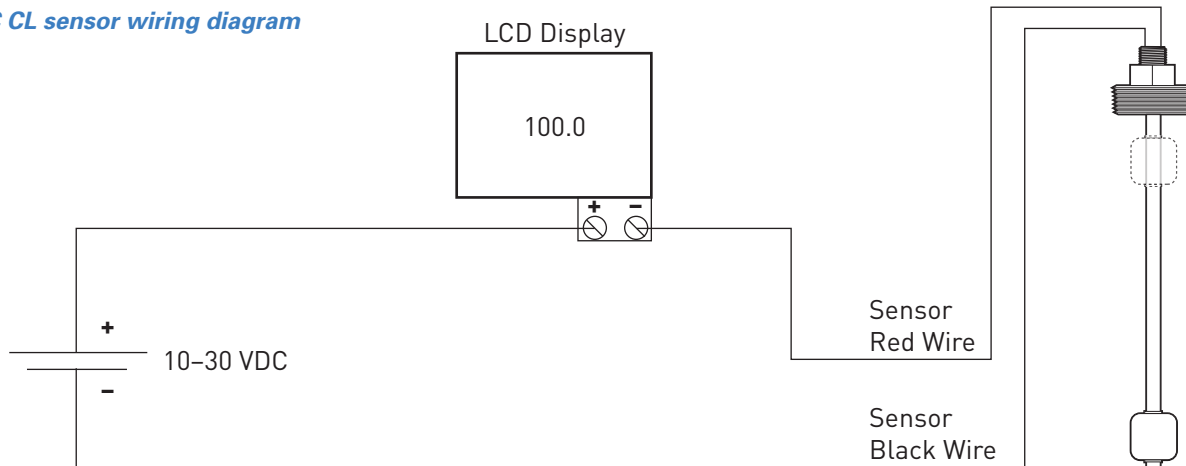

### Operation

The 0-5 VDC sensor operates on a power supply of 10-30 VDC. The sensor will provide a linear output between 0 and 5 VDC across the measuring range. When the float is at the bottom of the measuring range (furthest away from the fitting) the signal output will be 0 VDC. As the float moves closer to the fitting, the VDC output will increase until it reaches the top of the measuring range, providing a 5 VDC output. The VDC signal will change every 1/4" of float movement. The VDC value will change with every 1/4" of float movement. The value of VDC change per 1/4" of float movement equals 1.25 divided by total measuring range in inches.

Our 0-5 VDC sensors are reliable and easy to install. These sensors arrive at your plant, ready to install into your equipment. No calibration is needed. Simply install into your tank and connect the two wires — that's it. These sensors are tough. They are used in demanding applications with years of reliable, accurate performance. There is no drift and they never need calibration.

# Maintaining a float style level sensor

## Inspections

Scheduled maintenance of your liquid level sensor is suggested for applications where there is a potential for material buildup that would prevent the float from operating.

For cleaning, remove the sensor assembly from the tank and inspect for any material build up. If build up is present, select a cleaning solution that is compatible with the sensor's float and stem material and clean appropriately. If the float needs to be removed, make sure the top of the float and the float stop locations are identified (with a magic marker) to ensure the float goes back onto the stem with the proper orientation and the float stops are returned to their original locations. To confirm the float sensors operation, disconnect the wires from your control system.

For a float switch, connect an ohm meter or continuity meter to the sensor wires. Move the float up and down to verify the switch opens and closes in the designed float location. The design dimensions of the sensor are typically measured from the face of the mounting fitting. See the specific float switch drawing for more detailed information.

For a continuous level sensor, connect an independent power supply (12 or 24 VDC is most common) and appropriate meter wired as shown on the installation guide wire diagrams.

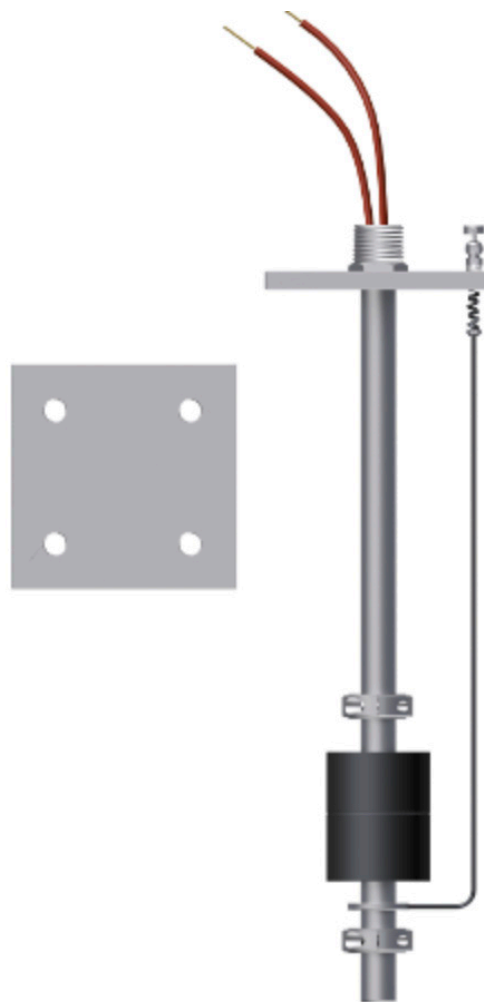

# Troubleshooting a float style level switch

If your **float level switch** sensor is not operating correctly, follow these steps:

1. Remove the sensor from your tank and disconnect the lead wires from your system
2. Verify the lead wire colors for the float switch that will be tested and connect an ohm meter to the lead wires. Verify the testing meter is set to measure ohms.
3. Move the float so it is positioned away from the sensor's fitting (if there is no fitting, then away for the end of the sensor where the lead wires exit) and observe the ohm meter reading. When the specific float switch is in the closed state, the meter should read 5 ohms or less, when the specific float switch is in the open state, the meter should read above 2 Meg ohms or infinite (Note, be sure the exposed test lead wires are not touching a conductive surface and are not touching a person's hands.)
4. Next move the float so that it is nearest the fitting (or where the lead wires exit the sensor) and observe the ohm meter. The meter should now read opposite of what it read prior to moving the float towards the fitting.
5. Move the float slowly to accurately observe when the meter is changing. Be sure to move the float all the way to the float stop and even rotate the float when it is against the float stop to insure there is not a change (multiple changes between the float stops) in your meter other than the designed float switch point.

If the ohm reading is not correct and/or the sensor is not operating properly, there are numerous potential reasons:

## **Float is not positioned properly or moving properly**

The float stops (clips or collars) may have come loose, may have been moved or may not be in the proper place. To confirm the float and float stops are in the proper position, measure the distance

of the center line of the float when the float is positioned in the center of the float stops. This measurement should be equal to (+/- 1/8") the designed level dimension. When the centerline of the float is at the designed dimension, the top and bottom float stops should be 3/16" away from the top and bottom end of the float. Inspect for debris or build up on the floats that would prevent the float from moving properly. Move each float fully up and down to make sure you get a single on and off switch point and not a "double read."

## **Shock or damage to the floats or the sensor assembly (bent, dented, etc.)**

Sensors need to be handled and installed with care. Check to make sure the shipping container was not damaged. An internal reed switch has a hermitically sealed glass housing that can break or can be "magnetically reset" so that it no longer is activated by the float. Floats have magnets inside that can break or become dislodged from rough handling or significant shock or vibration. If the float sinks, inspect the float for ruptures and check to see if the float is filled with liquid.

## **Excessive moisture around the wires exiting the sensor or connections**

Internal moisture typically results in a switch not fully turning off and possibly an internal short to ground. Inspect the wires exiting the sensor for signs of moisture. Although the lead wires are fully potted where they exit the sensors stem, it is possible for moisture to wick into the sensor between the edge of the lead wire and the epoxy. Note that wire and cable can wick moisture inside the wire insulation into the sensor. The source of liquid usually comes from the area where the insulation is stripped from the wires for connection.



## Reed switch failure

Reed switch failure can be a result of high voltage or current (or a short) exceeding the switch's switching capacity. Overpowered reed switches can fail either in the open or closed position. Typically, you will read resistance between 50 ohms to 10K ohms if the reed switch is stuck closed due to being overpowered. Sometimes a slight tap on the stem will cause the reed switch to become unstuck. If this happens, it is an indication that too much power is being applied to the reed switch. Though it may appear the reed switch is now working normally, it is recommended that the sensor is repaired, and new switches are installed as the original switch is damaged and potentially will cause a premature failure. In addition, the circuit must be examined to determine the reason for over powering the switch. If the switch was significantly over powered, it can be destroyed and it remains open.

## Float's specific gravity does not match the liquid that is being measured

The floats specific gravity must be less than the applications liquid specific gravity. If the floats specific gravity is greater than the liquids specific gravity, then the float will not float in the liquid and the switch will not change state. To estimate the specific gravity of the float, submerge the float in room temperature water (while the float is on a stem to keep the float upright) and estimate the percentage of the float that is submersed. The percentage is an estimate of the floats specific gravity.

## Wire colors do not match the level switch

When connected to one switch, attempt to activate/deactivate all switches to determine which switch is connected to what wire color.

# Troubleshooting a float style 4-20mA continuous level sensor

Verify that the wiring is correct and proper power is being applied to the sensor. If the system is still not working, completely disconnect the sensor from the system, apply 24VDC and monitor the sensor output with an independent mA meter. Wire the independent meter and power supply as shown in CL wiring diagram above. Move the float up to the  $\frac{1}{2}$  way point and confirm that the meter is reading approximately 12mA. Move the float to the  $\frac{1}{4}$  of the measuring range and the meter should read approximately 8mA. Move the float to the  $\frac{3}{4}$  of the measuring range and the meter should read approximately 16mA.

CL Wiring Diagram

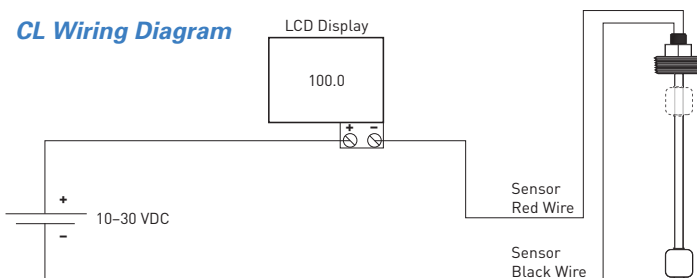

If the signal is not correct, double check that you have wired the meter according to the wiring diagram and the separate power supply is supplying 10-30VDC. Confirm that the wires are isolated from each other and not contacting any metal or conductive material.

This sensor should be wired by qualified, licensed technicians (CL wiring diagram). The 4-20mA loop powered sensor has two wires exiting the housing of the sensor. The red wire connects to signal (or + VDC), the black wire connects to - VDC. To protect the sensor, we suggest the power supply be wired with a fast blow fuse rated between 30mA and 100mA.

If the sensor is not operating correctly, contact Rochester for assistance.

## Troubleshooting a float-style 0-5VDC continuous level sensor

This sensor should be wired by qualified, licensed technicians (0-5 VDC CL sensor wiring diagram). The 0-5vdc continuous level sensor has three wires exiting the sensor. The red wire connects to the + of your meter or controller, the white wire connects to + VDC, the black wire connects to - VDC and the - of your meter or controller. To protect the sensor, we suggest the power supply be wired with a fast blow fuse rated between 30mA and 100mA.

Verify that the wiring is correct and proper power is being applied to the sensor. If the system is still not working, completely disconnect the sensor from the system, apply 24VDC and monitor the sensor output with an independent DC volt meter. Wire the independent meter and power supply as shown in 0-5VDC CL wiring diagram. Move the float up to the 1/2 way point and confirm that the meter is reading approximately 2.5 VDCs. Move the float to the 1/4 of the measuring range and the meter should read

approximately 1.25VDC. Move the float to the  $\frac{3}{4}$  of the measuring range and the meter should read approximately 13.75 VDC.

If the signal is not correct, double check that you have wired the meter according to the wiring diagram and the separate power supply is supplying 10-30VDC. Confirm that the wires are isolated from each other and not contacting any metal or conductive material.

If the sensor is still not operating, contact Rochester for assistance.

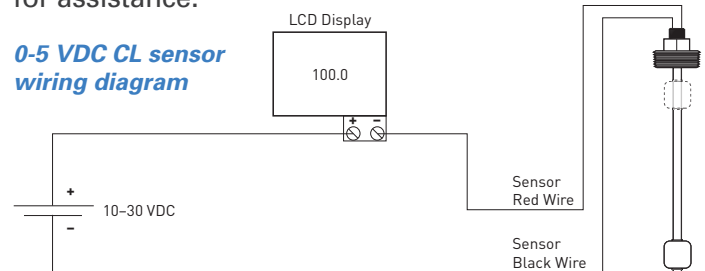

## Procedure for reversing a float to change the Normal Switch State

The operation of a Rochester float level sensor might be reversed from normally open to normally closed, or from normally closed to normally open by reversing the float orientation.

Note that "normal" position is referenced when the float is not floating and the threads are mounted on the top side of the tank.

### To reverse the float orientation:

1. Mark on the stem the current location of the retaining rings or set collars float stops with a black marker.
2. Mark the top side of the float so it is clear how it should be repositioned.
3. We suggest taking a picture of the float and float stops for reference before moving any components. Slide the bottom clip off the stem (Note: Do not over expand the clip as over expanding will destroy it).
4. Slide the float off the stem. Note that if multiple floats need to be reversed, it is necessary to repeat this process for each of the floats and float stops that need to be removed.
5. Flip the float over so the mark you made is now on the bottom and slide the float onto the stem. Replace the float stops back to the marked points. The float should now be able to freely move up and down about  $\frac{3}{8}$ " between the top float stop and the bottom float stop. Due to tolerances in the switch and float, it may be necessary to adjust the placement of the float stops so that the float operates with proper travel between the float stops.
6. To test, connect a continuity meter or ohm meter to the float switch. Slowly move the float up and down between the clips and note where the float is positioned when the switch changes state. Ideally the float should move a minimum of  $\frac{1}{8}$ " and a maximum of  $\frac{1}{4}$ " from the float stop prior to changing conditions. Adjust the float stop as needed to achieve this switch operation and float travel guidelines. Be sure to check that the switch only changes state once as the float travels from the bottom float stop to the top float stop.

## A brief history of float switches

A **float switch** is a device used to detect the level of liquid within a tank. The switch may be used to control a pump or send a signal to an indicator, alarm, controller or other devices.

A search of the patents for float level sensors and float switches will uncover several patents dated back to the late 1800s. One invention (Figure 8) references a magnetic float used to induce movement of needles that will give an indication of the liquid level. Like everything else, float switches have progressed much through the years.

Current float level sensors are certainly more sophisticated, reliable and versatile than previous devices. Today's liquid level float sensors, also known as float switches, float level switches and float level sensors, use permanent magnets mounted in a float that slides up and down a stem. The float sensor stem contains magnetically activated reed switches that typically are calibrated to the float's magnetic field. The reed switch is activated as the float's magnetic field surrounds it. This results in switch activation as the float rises and falls with the liquid level. The activating magnet is sealed in the float and the stem's internal reed switch is hermetically sealed and electrically isolated from the stem. The stem is made of nonmagnetic metals or rugged, engineered plastics (so to not interfere with the magnetic field). This vertical float level sensor design results in a switch point accuracy of  $\pm 1/8$  inch. Multi-point float switches use a separate reed switch for each level point being monitored.

Side-mounted float switches, also known as horizontally mounted magnetic float switches, use different actuation methods to accommodate their horizontal mounting position. The basic principle, however, is the same: As a direct result of rising or falling liquid level, a magnetic field is moved into the proximity of a reed switch, causing its actuation.

Figure 8. U.S. Patent Office, filing No. 530,592  
MAGNETIC WATER GAGE, Patented December 11, 1894

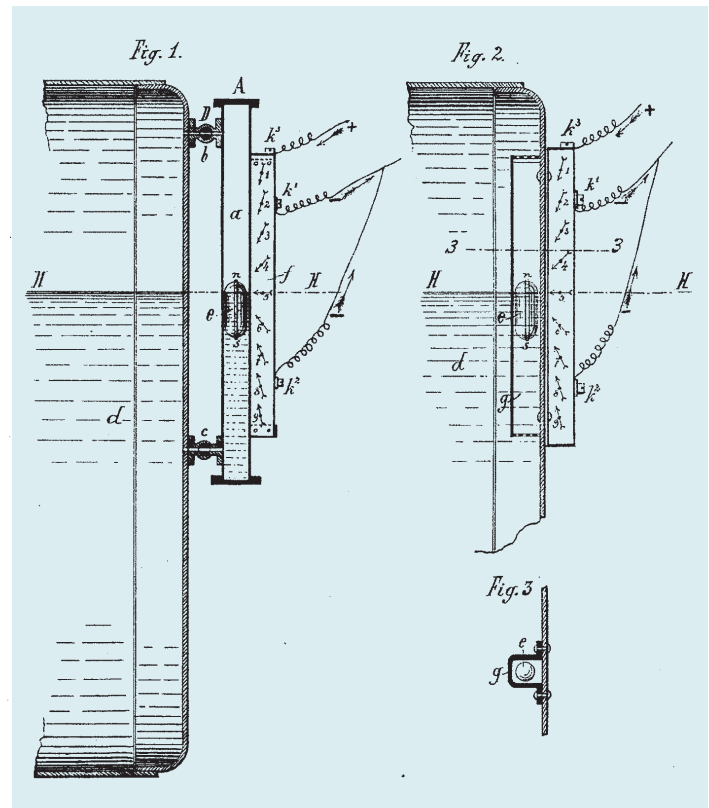



# APPENDIX 1: Hazardous location considerations

**Note: This document is for informational purposes only. Associated apparatus must be installed in accordance with its manufacturers control drawing and Article 504 of the National Electrical Code (ANSI/NFPA 70) for installation in the United States, or Section 18 of the Canadian Electrical code for installations in Canada. Suitability for installation applications is at the discretion of the authority having jurisdiction (AHJ).**

At times, sensors must be installed in areas where combustible dust, vapors and gases are used or may be present. These areas are commonly referred to as “hazardous locations,” and are defined by the National Electrical Code

(NEC) in the US, or the Canadian Electrical Code (CEC) in Canada. When equipment must be installed in hazardous locations, there are strict requirements to prevent inadvertent ignition of combustible dust, gases and vapors.

In North America, the categorization of hazardous areas is done in accordance with NEC article 500 and other associated articles. The class rating will tell you if the hazardous material is a gas or is dust. The division rating indicates the probability of the hazard being present; and the group reveals the type of the hazardous substance and its volatility.

## Condition descriptions

There are three classes of hazardous conditions:

Class I Locations: Gases and Vapor	Class II Locations Combustible Dust	Class III Locations Fibers and Filings
<ul style="list-style-type: none"> <li>• Petroleum refineries, and gasoline storage and dispensing areas</li> <li>• Dry cleaning facilities where vapors from cleaning fluids are present</li> <li>• Spray finishing areas</li> <li>• Aircraft hangars and fuel servicing areas</li> <li>• Utility gas plants and operations involving the storage and handling of liquefied petroleum gas or natural gas</li> </ul>	<ul style="list-style-type: none"> <li>• Grain elevators</li> <li>• Flour and feed mills</li> <li>• Plants that manufacture, use or store magnesium or aluminum powders</li> <li>• Plastic, medicine and firework manufacturers</li> <li>• Starch or candy producers</li> <li>• Spice-grinding plants, sugar plants and cocoa plants</li> <li>• Coal preparation plants and other carbon handling or processing areas</li> </ul>	<ul style="list-style-type: none"> <li>• Textile mills, cotton gins</li> <li>• Cotton seed mills, flax processing plants</li> <li>• Plants that shape, pulverize or cut wood and create sawdust or filings</li> </ul>

Most hazardous locations for liquid level sensors are Class I locations. This guide will focus on Class I locations because the level sensors are mostly used in liquids that are typically hazardous when in a gas or vapor form.

Class I locations have two divisions of hazardous conditions:

**Division 1:** The gases or vapors are always present at sufficient concentrations to be an explosion hazard.

**Division 2:** The gases or vapors may be present, and if they are, they are likely to be in sufficient concentrations to be an explosion hazard.

In Class I locations there are four Groups (A, B, C, D) that are classifications of substances and their degree of volatility, with A being the most hazardous and D being the least volatile group for gases and vapors.

**Group A:** Acetylene

**Group B:** Hydrogen and manufactured gases containing hydrogen

**Group C:** Ethyl-ether vapors, ethylene, or cyclo-propane

**Group D:** Gasoline, hexane, naphtha, benzene, butane, propane, alcohol, acetone, benzol, lacquer

### Basics of explosion risks

For an explosion to occur, there must be three basic conditions present:

1. A flammable liquid, vapor or combustible dust must be present in sufficient quantity
2. The flammable liquid, vapor or combustible dust must be mixed with air or oxygen in the proportions required to produce an explosive mixture
3. A source of energy must be applied to the explosive mixture.

In applying these principles, the quantity of the flammable liquid or vapor that may be present and its flammable characteristics must be recognized.

### Sources of ignition

A source of energy is needed to create an explosion when flammable gases or combustible dusts are mixed in the proper proportion with air. Equipment such as switches, pushbutton stations, plugs and receptacles, can produce arcs or sparks in normal operation when contacts are opened and closed. This could easily cause ignition. Electrical safety, therefore, is of crucial importance. The electrical installation must prevent accidental ignition of flammable liquids, vapors and dusts released to the atmosphere.

### The difference between intrinsically safe and explosion proof

The two most common methods of protecting a sensor circuit in a hazardous location are Intrinsically Safe and Explosion Proof.

When using “explosion-proof rating” to address the hazardous rating protection, the internals of the sensor and affiliated equipment must be engineered to contain an internal explosion and avert a much larger detonation.

An “intrinsically safe rating” means the electronics are designed and or controlled so that a spark does not create enough energy to ignite the substances in the hazardous location.

### Intrinsically safe equipment

Intrinsic safety (I.S.) is a protection method for electrical equipment used in hazardous locations where the energy allowed into and stored within an area is limited to a level that is incapable of causing ignition. I.S. equipment is designed and evaluated to ensure that the amount of electrical energy stored within the device is reliably limited to predetermined safe levels.

The use of intrinsically safe equipment is suitable to process control instrumentation such as float switches and level transmitters because these electrical systems lend themselves to low energy requirements. An I.S. barrier must be used to limit the amount of energy entering the hazardous area and the I.S. barrier must be selected to be compatible with the connected IS equipment both from a safety and functional perspective.

### Explosion proof enclosures

The explosion-proof protection method relies on equipment and wiring enclosures to prevent an internal ignition from escaping to the surrounding atmosphere. Such housings usually are made of cast aluminum or stainless steel and are of enough mass and strength to safely contain an explosion should flammable gases or vapors penetrate the housing and the internal electronics or wiring cause an ignition.

In Class I, Division 1 and 2 locations, conventional relays, contactors and switches that have arcing contacts should be enclosed in explosion proof housings.

The NEC defines explosion proof apparatus as “apparatus enclosed in a case that is capable of withstanding an explosion of a specified gas or vapor that may occur within it and of preventing the ignition of a specified gas or vapor surrounding the enclosure by sparks, flashes, or explosion of the gas or vapor within, and that operates at such an external temperature that a surrounding flammable atmosphere will not be ignited thereby.” These enclosures must prevent the ignition of an explosive gas or vapor that may surround it. In other words, an explosion inside the enclosure must be prevented from starting a larger explosion on the outside.

## Intrinsically safe versus explosion proof: Advantages and disadvantages

### Explosion proof

Although an explosion proof system for liquid level sensor applications is generally considered somewhat simpler to design, it is generally more expensive to install because of the high cost of running field wiring inside a conduit, which must be sealed between the safe and hazardous areas. Explosion-proof equipment can also be more difficult to maintain since either the area must be known to be non-hazardous or the equipment must have the energy drained before covers can be removed.

Liquid level sensor explosion proof systems have their own hazards, particularly because they do not actually avoid creating an explosion. The housing is designed to contain the explosion. The risk is that with corrosion, nicks or cuts to the housing, or if screws are not screwed in all the way, a much larger explosion could occur outside the housing.

### Intrinsically safe

Liquid level sensor intrinsically safe systems are commonly considered safer, less expensive, and easier to install and maintain. With intrinsically safe designs, system integrity is less of a concern because explosions cannot occur. Intrinsically safe liquid level sensor systems offer significant labor savings over traditional explosion proof protection methods because there are no heavy conduits or bolted enclosures. Material costs are typically less because a standard enclosure is the only major expense for mounting the barriers. And unlike most explosion protection methods, intrinsically safe systems operate seamlessly with retrofit applications and with modern technologies such as fieldbus. The affinity to newer technology is one reason intrinsically safe designs are becoming a preferred hazardous location protection method.

The main disadvantage of intrinsically safe systems is that it can be used for low power circuits. Typically, measuring and control instruments (like level sensors, level transmitters etc.) are low power circuits which makes them a good candidate for Intrinsically Safe designs.



## Selecting the best choice

Intrinsically safe systems seem to be considered the preferred solution for low power sensor circuits including level switches, level transmitters, RTDs, pushbuttons, and low-power solenoids.

This approach is embodied in the principle of intrinsically safe systems where the sparks are prevented from ever causing an explosion. In contrast, the explosion proof method of protection is mitigative: when sparking happens in a hazardous area, the explosion does occur, but the effects are mitigated to some extent.

### Designing Intrinsically safe sensor circuits using simple and non-simple apparatus'

#### Simple apparatus (switches) vs non-simple apparatus (transmitters)

An intrinsically safe apparatus is classified either as a simple apparatus or non-simple apparatus.

*Simple apparatus* is defined in paragraph 3.12 of ANSI/ISA-RP 12.6-1987 as any device which will neither generate nor store more than 1.2 volts, 0.1 amps, 25 mow or 20  $\mu$ J. Float switches, simple switches, contacts, thermocouples, and resistors are examples of a simple apparatus. These devices themselves do not need to be approved as intrinsically safe when connected to an approved intrinsically safe barrier.

*A non-simple apparatus*, on the other hand, can create or store levels of energy beyond what is listed above as safe and thus the device itself needs to carry an intrinsically safe rating and be connected to an approved intrinsically safe barrier. Typical examples are transmitters, transducers, and relays. These approved intrinsically safe devices will have a required control drawing that indicates the intrinsically safe barrier parameters and wiring requirements.

## Float Switches

A float switch is considered a simple apparatus by UL's Hazardous Location approving agency. A simple apparatus does not require a special hazardous location rating (Class I, II or III); however, it does require connection to an appropriate intrinsically safe barrier. The intrinsically safe barriers have certifications that are extended to the attached simple apparatus when installed properly.

## Transmitters

A continuous output transmitter is considered a non-simple apparatus by UL's Hazardous Location approving agency. A non-simple apparatus requires a hazardous location rating and needs to be connected to an appropriate intrinsically safe barrier. Refer to the control drawing below for an example of our continuous level sensor with intrinsically safe barrier.

**Note: this document is for informational purposes only. Associated apparatus must be installed in accordance with its manufacturers control drawing and Article 504 of the National Electrical Code (ANSI/NFPA 70) for installation in the United States, or Section 18 of the Canadian Electrical code for installations in Canada. Suitability for installation applications is at the discretion of the authority having jurisdiction (AHJ).**

## APPENDIX 2: Understanding electrical ratings of float switches

A common inquiry about float switches is if the switch can properly handle the applications electrical load. It is easier to determine electrical load capabilities if you understand how the liquid level sensors internal components work. Float level switches utilize reed switch technology. Specifically, they are glass encapsulated, hermetically sealed, magnetically actuated reed switches. When a magnetic field (contained in the float) surrounds or comes in close proximity to the reed switch, the contact changes state. The size of the reed switch limits its electrical load handling capability. The internal reed switches can only handle a relatively small load. See reed switch ratings below for more detail.

### Reed switch ratings

When selecting your float level sensor, it is important that your electrical load requirements do not exceed the switch's rating. Care must be taken so that your load does not exceed ANY of the maximum ratings for wattage, current, and voltage of the reed switch selected. See the following table for an example of maximum reed switch electrical parameters.

### Maximum wattage, voltage and current ratings of reed switches

Switch	Max. wattage	Max. voltage	Max. current
10W switch	10 watts	175 VAC/VDC	500 mA
50W switch	50 watts	265 VAC/VDC	1 amp
100W switch	100 watts	265 VAC/VDC	3 amp

To determine if your electrical load will not exceed the float switches capability, determine the operating voltage and multiple that by the current draw of your load. This will give you the Wattage of your electrical load. (Watts=Volts x Amps) Now compare your wattage, voltage and current values of your electrical load to insure all 3 of these values are less than the maximum ratings of the switch. Remember if any one

of your load parameters exceeds the switches parameters, a different switch or different circuit design must be used.

Assuming some common load voltages, the following table shows the maximum amperage that can be drawn through the system.

### Maximum current allowed based on voltage used and wattage of reed switch selected

Wattage of selected reed switch	Voltage used	Maximum current (amps)
10W	240 AC	0.04
	120 AC	0.08
	24 DC	0.4
50W	240 AC	0.2
	120 AC	0.4
	24 DC	1.0
100 W	240 AC	0.4
	120 AC	0.8
	24 DC	3

— Formula used:  $I_{max} \text{ (current)} = \text{Watts/Voltage}$

— These ratings are for resistive loads only. For inductive loads, it is important to determine your load's peak in rush current and voltage

**Note: The power drawn by loads can be expressed in either Watts (W) or Volt-Amps (VA). The power in Watts is the actual power drawn by the equipment and Volt-amps is used for apparent power in AC circuits and equals Volts x Amps. Volt-Amps is the product of voltage and current, without considering the type of load (resistive or inductive). When talking about resistive loads, Watts and VA can be used interchangeably in the chart above.**

## Switching Resistive, inductive and capacitive loads

It is important to understand the characteristics of your load that you are switching to ensure that the float switch can handle the electrical load. The electrical ratings of the float switch are commonly defined as peak load ratings. Resistive loads or “dry contact” loads (Common for PLC’s or custom controllers) are typically stable because the switching load is similar to the ongoing carrying load. Inductive loads, such as a solenoid, small motor, or light bulbs can have “flyback power” where the peak voltage or current and peak wattage can be 10 times – 20 times (or more) than the rated steady state electrical load when the circuit opens. Capacitive loads “store” energy and when the switch is opened up, a large power spike can result as the stored energy is drained from the load. An example of this would be long lead wire or electrical circuitry with a large current load. If these load characteristics are not taken into consideration, these peak currents and voltage spikes can easily damage your float level sensor switch.

### LOAD EXAMPLES:

- Resistive load: Resistors, dry contact input, controllers
- Capacitive Loads: Lead wires that exceed 200 ft, electrical equipment
- Inductive Loads: Relay’s, Solenoids, Light bulb

### Designing for Inductive loads and Capacitive loads

If your load’s capacitive or inductive peaks are not managed correctly, the internal reed switch can be damaged and can result in pre-mature sensor failure. One option to protect the sensors’ reed switch is to design a general-purpose isolation relay in the application. In this scenario, the float switch will be connected to the relay coil, although this is an inductive load, typically will have a peak current less than 500 mA. The float switch will control the relay coil and open and close the relay’s output contacts. The relay

contacts carry the high in-rush current created by the applications inductive load.

### Design suggestions for both DC INDUCTIVE and CAPACITIVE LOADS

#### DC voltage lamps, DC Inductive or DC Capacitive Loads:

When switching DC voltage inductive or capacitive loads, a high peak power spike can be experienced when the switch opens. These “fly back” spikes can be 10 times or more the normal voltage and/or current state. One solution to protect the switch in these situations is to install a diode in parallel with the DC load. This diode provides a path for the fly back current that is generated from the inductive field, protecting the reed switch from being exposed to this power spike. A “1N4004” diode is a common choice. Install the diode so the cathode side (white ring) is connected to the positive power side of the load.

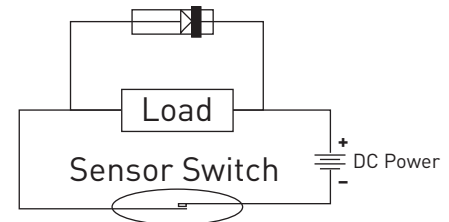

Diode circuit diagram

(Diode circuit diagram)

Alternatively, another option is to install a resistor in series with the reed switch. It is important to understand the resistor could affect your applications performance. We suggest you test to insure the additional resistance added to your electrical load does not cause any performance problems. For best protection, the larger the resistor value, the more protected your switch will be. If your circuitry allows for it, a 470-ohm resistor is a common choice.

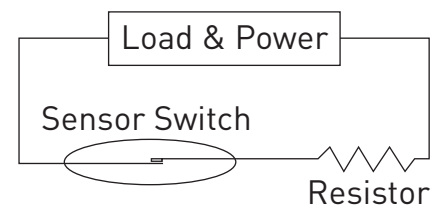

Resistor circuit diagram



## Design suggestions for both AC INDUCTIVE and CAPACITIVE LOADS

### AC Relay Coil, AC Solenoid, AC Motors and other AC inductive loads:

AC inductive loads can have peak power spikes 10-20 times greater than the rated full load power. This peak power spike exists both when the switch closes and when the switch opens (Lasting a fraction of a second or longer). Although this power spike only lasts a very short time, it will still damage and/or destroy the switch. There are several solutions to help reduce the impact of the AC power spikes to the sensor's switch.

Across the sensor's switch (parallel wiring), wire a resistor and capacitor in series. Calculate the approximate resistor value by multiplying 2 times the peak voltage value divided by the current across the switch. A resistor within 20% of this value is a good starting point. Commonly a .1uF capacitor is used. See (RC network diagram).

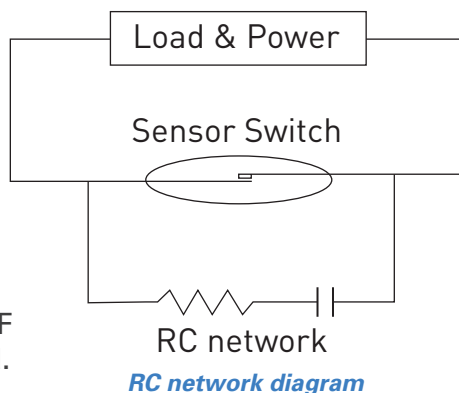

Another option is to wire a varistor in parallel with the sensor's switch. Consult with the varistor manufacturer to determine the correct model and rating of the varistor for your application. (Varistor diagram)

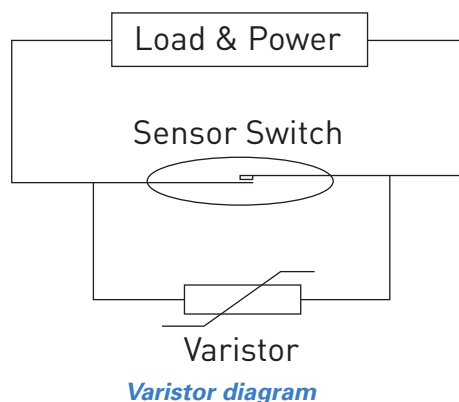

### In summary

Electrical current overload is a common cause of failure for reed switch-based liquid level switches. If proper measures are not taken with your sensor design, switch failure will likely occur when switching inductive and capacitive loads. When you take the proper protective measures to ensure that your liquid level switch is operated at its rated electrical load, you can expect this highly reliable reed to deliver millions of switching cycles over the course of its lifetime.

## APPENDIX 3: Threaded Connections

Threaded Fittings are some of the most common way of mounting float style liquid level sensors:

The most common types of threaded fittings are NPT (national pipe thread) and straight threads (SAE or BSP).

NPT threads create a seal because the threads are tapered. The tapered fitting threads and the adapter seal together due to the friction created in the friction of tightening two tapered threads. For pressure seal using NPT fittings, it is recommended to use a pipe sealant. The pipe sealant helps create a seal as well as prevents galling of stainless steel fittings. Straight threads do not seal by tightening them together. To seal straight threads an external seal, such as gaskets or O-rings are required.

### NPT assembly instructions

1. Inspect the tank fitting port and sensor fitting to ensure that both are free of contaminants and burrs.
2. Apply a stripe of an anaerobic liquid pipe sealant around the male threads leaving the first two threads uncovered. If no liquid sealant is available, wrap Teflon tape 1-1/2 turns in a clockwise direction, viewed from the pipe end, leaving the first two threads uncovered.
3. Screw the fitting finger tight into the port.
4. Wrench tighten the fitting 2-4 turns past finger tight position (based on fitting size) so that total thread engagement is achieved as shown in the table 1 below.
5. An NPT fitting's engagement length – the amount of overlap between the male and the female fittings – depends on pipe size and the applied torque. In the figure below, the dimension below each fitting is the hand tight engagement length.

**CAUTION: Never back off an installed pipe fitting to achieve proper alignment. Loosening installed pipe fittings will corrupt the seal and contribute to leakage and failure.**

Torque installation of pipe fittings is not recommended. Thread taper, quality, port and fitting materials, plating thickness and types, thread sealants, and orientation reduce the reliability of a torqued connection.

One of the challenges with stainless steel NPT threads is that tightening the fittings without lubrication can cause galling, making it very difficult to remove the sensor in the future. Thread sealant or Teflon tape is needed to prevent galling. If using Teflon tape, be careful to apply it sparingly as the extra material can prevent the threads from sealing properly.

## How to quickly determine the nominal size of a male NPT thread

NPT fitting sizes do not match the outside or inside thread diameter. An NPT fitting's engagement length, the amount of overlap between the male and the female fittings, depends on pipe size and the applied torque. In the figure 13 following, the dimension below each fitting is the estimated hand tight engagement length.

Fitting sizes may also be referred to using a dash number. Dash numbers refer to the size in sixteenths of an inch using the numerator over a denominator of 16. In the example above, 1/2" pipe thread is converted to 8/16" and written as -08. O-ring fittings used with hydraulic straight thread fittings are referred to in this way.

### NPT dimensions

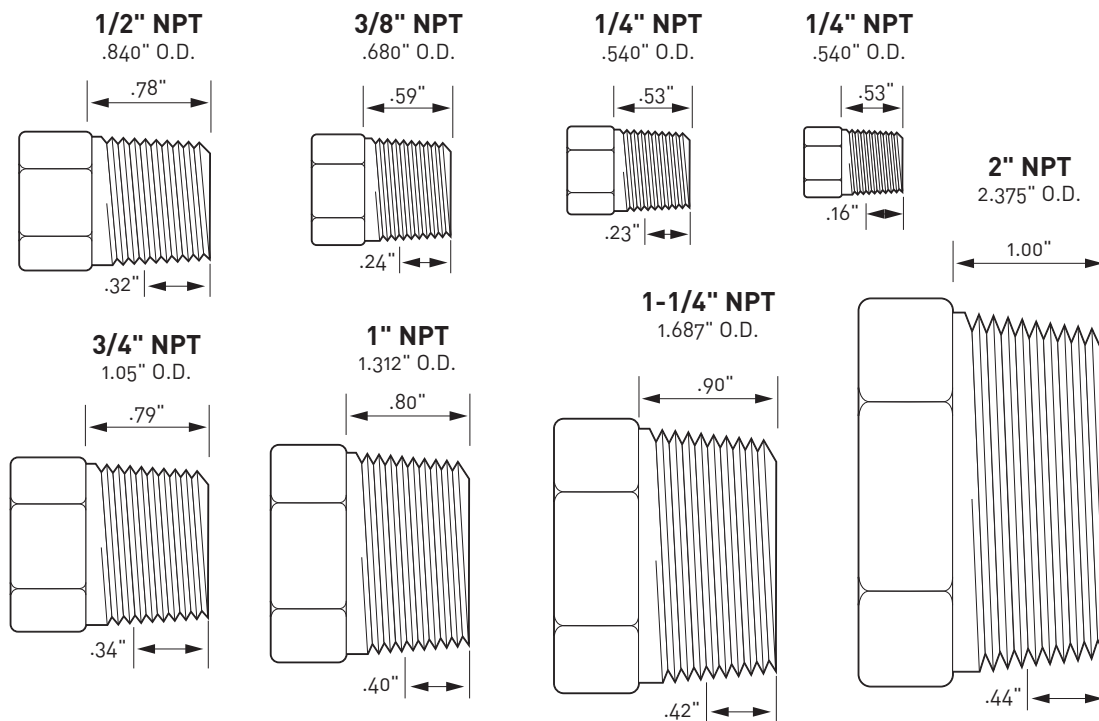



## How to determine the nominal size of an NPT thread

NPT fitting sizes do not match the pipe's actual physical dimensions. The outside diameter (OD) of the pipe fitting should be measured and compared to the reference table 1 following for identification.

### Male threads

Referencing NPT Dimensions, measure the outside diameter of the large portion of the thread, shown as A. Find the figure nearest this dimension in column 1 or 2 of the table 1. The number in column 3 is then the nominal pipe thread size. For example, a male thread with an A dimension of 2 3/8" will have a nominal pipe fitting size of 2" as shown in table 1.

### Female threads

Referencing Pipe Thread Dimensions, measure the top diameter of the thread, shown as B. Find the figure nearest this dimension in column 1 or 2 of the table 1. The dimension in column 3 is then the nominal pipe thread size. For example, a female thread with a B dimension of 2 3/8" will have a nominal pipe fitting size of 2" as shown in 1.

*Pipe thread dimensions*

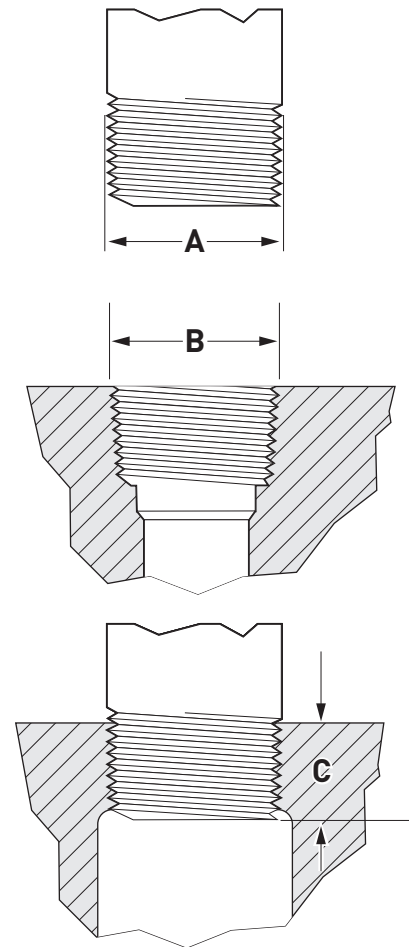

**Table 1**

<b>Nominal Pipe Size</b>	<b>Dash Size</b>	<b>OD/ID in decimal inches</b>	<b>TPI threads per inch</b>	<b>Normal engagement for a tight joint (dimension "C")</b>
1/4"	-04	0.540"	18	0.4018"
3/8"	-06	0.675"	18	0.4078"
1/2"	-08	0.840"	14	0.5337"
3/4"	-12	1.050"	14	0.5457"
1"	-16	1.315"	11-1/2	0.6828"
1-1/4"	-20	1.660"	11-1/2	0.7068"
1-1/2"	-28	1.900"	11-1/2	0.7235"
2"	-32	2.375"	11-1/2	0.7565"
2-1/2"	-40	2.875"	8	1.1375"
3"	-48	3.500"	8	1.2000"
3-1/2"	-56	4.000"	8	1.2500"
4"	-64	4.500"	8	1.300"