

Five Level Configurator – Build to Order

We excel in **LOW COST** and **HIGH QUALITY**

MANY OTHER VARIATIONS AND OPTIONS ARE AVAILABLE

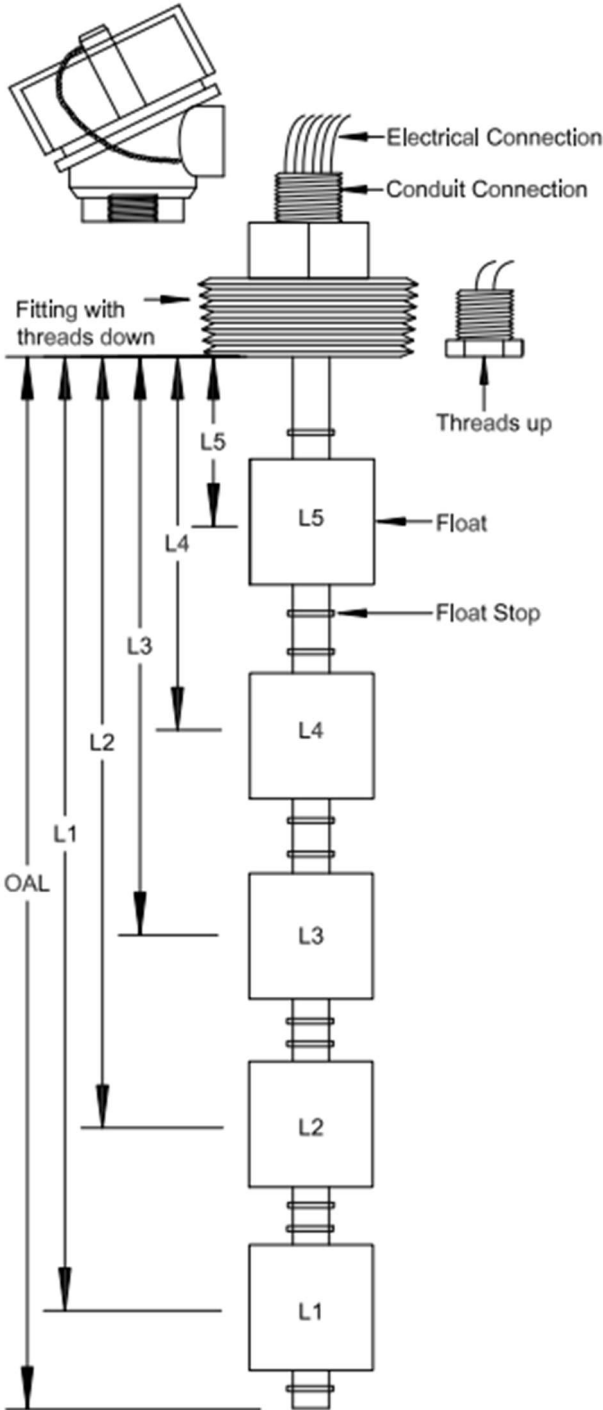

HOUSING:

- Nema 4X Explosion Proof
- Watertight
- NA

ELECTRICAL CONNECTION:

- Wire
- Cable
- Connector (specify) _____

CONDUIT CONNECTION:

- 1/2" NPT
- Other _____
- NA

FITTING AND STEM MATERIAL:

- SS
- Brass
- PVC
- Poly
- Teflon

FITTING SIZE (NPT):

- 1/4"
- 1/2"
- 3/4"
- 1"
- 1 1/4"
- 1 1/2"
- 2"
- Flange _____
- Other _____

THREAD ORIENTATION:

- Threads down (*threads from outside of the tank*)
- Threads up (*threads from inside of the tank*)

LEAD LENGTH: _____"

FLOAT STOPS:

- Retaining ring
- Set collar

FLOAT MATERIAL:

- SS
- Buna
- Poly
- Teflon
- PVC

SWITCH TYPE:

- SPST
- SPDT

SWITCH RATING:

- 10 watt (500ma)
- 50 watt (1 amp)
- 100 watt (3 amp)

ACTUATION:

- L5 _____"
- L4 _____"
- L3 _____"
- L2 _____"
- L1 _____"

OPERATION:

- N.O.
- N.C.
- N.O.
- N.C.
- N.O.
- N.C.
- N.O.
- N.C.
- N.O.
- N.C.

SPECIFIC GRAVITY:

- .60sg
- .93sg
- .60sg
- .93sg
- .60sg
- .93sg
- .60sg
- .93sg
- .60sg
- .93sg

Minimum actuation is 1" Maximum actuation is 235"

OPTIONS:

- Shroud
- Field Adjustable Length
- Thermocouple _____
- Temp Switch N.O. or N.C. _____ °F set point
- Centering Disk
- Compression Union
- Thermistor _____